

# HAM-LET HOSES

METAL | PTFE | RUBBER | NYLON PFA | COMPONENTS  
EXPANSION JOINTS

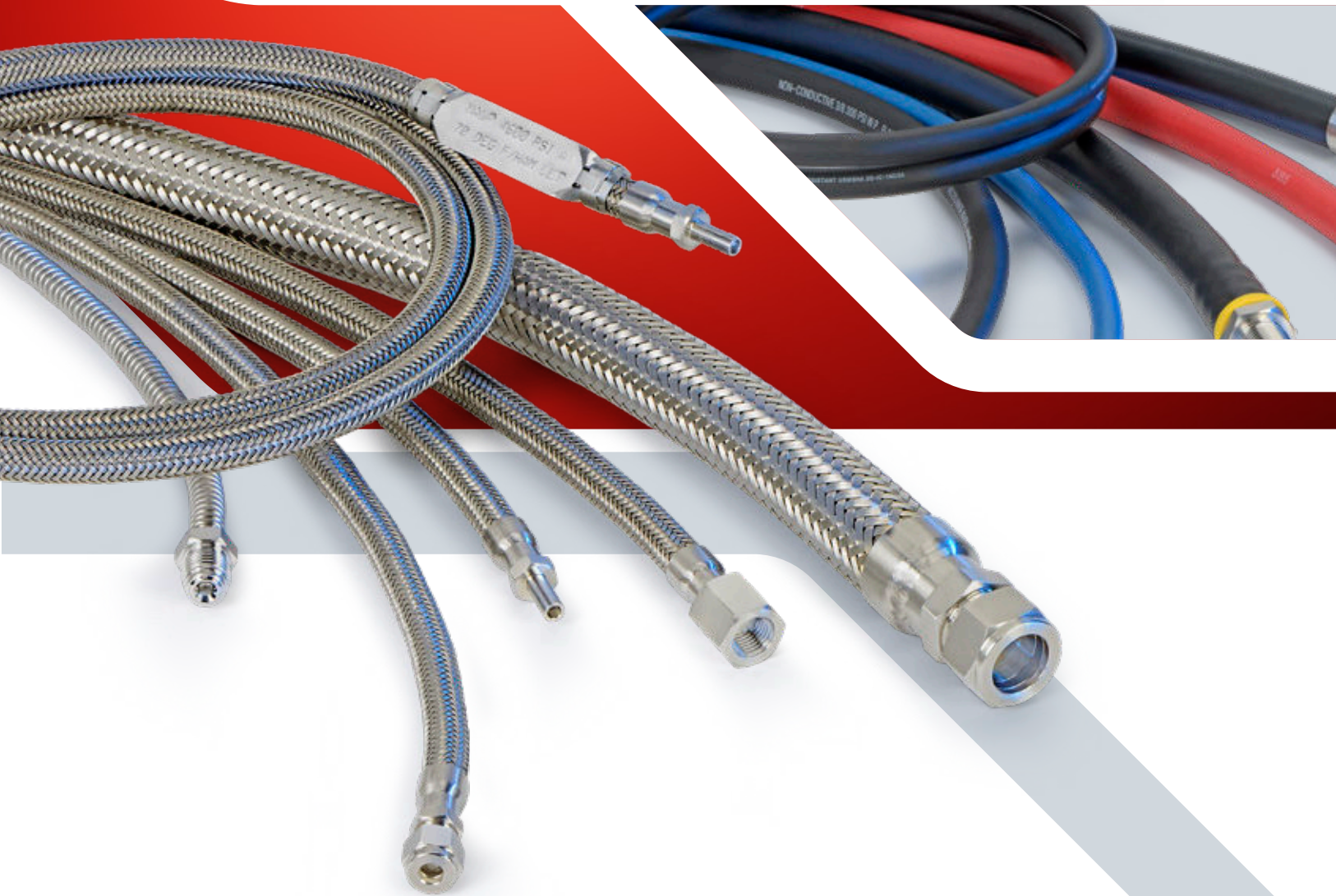

# INDEX

## HAM-LET HOSES ASSEMBLIES

HAM-LET METAL HOSES	07
HAM-LET PTFE HOSES	25
HAM-LET RUBBER HOSES	33
HAM-LET NYLON HOSES	37

## HAM-LET HOSES COMPONENTS

METAL HOSES	43
PTFE HOSES	55
RUBBER HOSES	65
PFA HOSES	71

## EXPANSION JOINTS

EXPANSION JOINTS	75
------------------	----

## Ham-Let Hoses End Connections

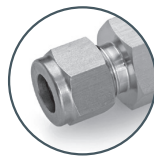

LET-LOK®

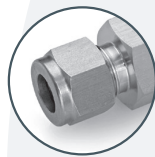

ONE-LOK®

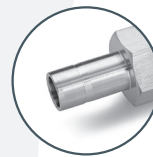

Tube Adapter

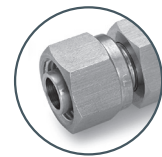

Pre swaged  
tube adapter



Male NPT



Female NPT

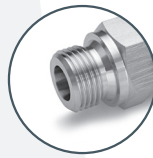

Male BSPP



Female BSPP



Male Face  
Seal Swivel



Female Face  
Seal Swivel

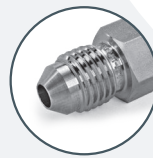

Male  
JIC 37° Flare



Female  
JIC 37° Flare

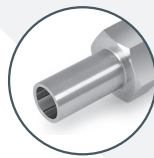

Butt Weld



Sanitary flange



UH Line

## Metal Hoses



**SHF SERIES** 10  
General Use



**SHE SERIES** 11  
Extra Flexible



**SHJ SERIES** 12  
Higher-pressure More Flexible



**SHU SERIES** 13  
Ultra High Pressure



**SHV SERIES** 14  
Formable



**SHS SERIES** 15  
Standard Use



**SHP SERIES** 16  
Industrial Gas Application



**SHG SERIES** 17  
Gas Application



**COMPONENTS** 43

## PTFE Hoses



**THT SERIES** 27  
Smooth Core



**THS SERIES** 27  
Silicon Covered Smooth Core General Use



**THC SERIES** 28  
Convuluted Core



**THB SERIES** 28  
Smooth Core Fiber braid



**THN SERIES** 29  
Convuluted Insulated PTFE Core Aramid Braided



**THP SERIES** 29  
Red Silicon Covered Smooth Core



**THR SERIES** 30  
Smooth Core with additional fiber braid



**COMPONENTS** 55

## Rubber Hoses



**RHG SERIES** 34  
General Use



**COMPONENTS** 65

## Nylon Hoses



**NHG SERIES** 38  
Nylon Reinforced



**NHT SERIES** 39  
Nylon Reinforced SAE100R8



**NHP SERIES** 40  
Nylon Reinforced SAE 100R7

## PFA Hoses



**PHG SERIES** 73  
Standard Use



**COMPONENTS** 71

# HAM-LET Hoses Quick Selection Guide

See Ordering information on page 18 and 23

Inside Diameter inch (mm)																	
Hose Series	Number of Braids	1/4 (6.35)		3/8 (9.53)		1/2 (12.70)		3/4 (19.05)		1 (25.40)		1 1/4 (31.75)		1 1/2 (38.10)		2 (50.80)	
		Working Pressure psi (bar)	Dynamic Bend Radius inch (mm)	Working Pressure psi (bar)	Dynamic Bend Radius inch (mm)	Working Pressure psi (bar)	Dynamic Bend Radius inch (mm)	Working Pressure psi (bar)	Dynamic Bend Radius inch (mm)	Working Pressure psi (bar)	Dynamic Bend Radius inch (mm)	Working Pressure psi (bar)	Dynamic Bend Radius inch (mm)	Working Pressure psi (bar)	Dynamic Bend Radius inch (mm)	Working Pressure psi (bar)	Dynamic Bend Radius inch (mm)
<b>SHF</b> General use Standard Metal Hose T321, T316L, T304L See page 10	0	90 (6)		70 (5)		70 (5)		43 (3)		43 (3)		43 (3)		28 (2)		14 (1)	
	1	1800 (124)	4.5 (114)	1558 (107)	5.0 (127)	1186 (82)	5.5 (140)	898 (62)	8.0 (203)	718 (50)	9.0 (229)	645 (44)	10.0 (254)	531 (37)	11.0 (279)	449 (31)	13.0 (330)
	2	2700 (186)		2336 (161)		1779 (123)		1347 (93)		1077 (74)		968 (67)		797 (55)		674 (46)	
<b>SHE</b> Extra flexible Most Flexible Hose T321, T316L, T304L See page 11	0	90 (6)		70 (5)		70 (5)		43 (3)		43 (3)		43 (3)		28 (2)		14 (1)	
	1	1800 (124)	3.7 (94)	1558 (107)	4.0 (102)	1186 (82)	4.4 (112)	898 (62)	6.4 (163)	718 (50)	7.1 (180)	645 (44)	7.9 (201)	531 (37)	8.7 (221)	449 (31)	10.3 (262)
	2	2700 (186)		2336 (161)		1779 (123)		1347 (93)		1077 (74)		968 (67)		797 (55)		674 (46)	
<b>SHJ</b> Over flexible Higher-Pressure More Flexible T321, T316L, T304L See page 12	0	450 (31)		400 (28)		400 (28)		220 (15)		190 (13)		200 (14)		90 (6)		105 (7)	
	1	3000 (207)	5.5 (140)	2400 (165)	8.5 (215)	2400 (165)	10.0 (254)	1100 (76)	8.0 (203)	1000 (69)	9.0 (229)	900 (62)	12.0 (305)	750 (52)	13.0 (330)	800 (55)	15.0 (381)
	2	4000 (276)		3300 (226)		3200 (221)		1650 (114)		1400 (97)		1350 (93)		1200 (83)		1150 (79)	
<b>SHU</b> Ultra high pressure Higher Pressure T321 & T316L See page 13	0	500 (34)		400 (25)		200 (14)		250 (17)	4.5 (114)	180 (12)	7.0 (178)	190 (13)	9.5 (241)	110 (8)	11.5 (292)	100 (7)	12.0 (305)
	1	5000 (345)	4.5 (114)	3500 (241)	7.0 (177)	2700 (186)	8.5 (203)	2650 (182)	10.0 (254)	2500 (172)	11.0 (279)	1775 (122)	12.5 (318)	1450 (100)	13.0 (330)	1100 (76)	14.0 (356)
	2	6000 (414)		5000 (344)		4500 (310)		3600 (248)	10.0 (254)	3000 (207)	11.0 (279)	2600 (179)	12.5 (318)	2200 (152)	13.0 (330)	1675 (115)	14.0 (356)
	3	-		-		-		-	-	-	-	3000 (207)	14.0 (356)	-	-	-	-
<b>SHV</b> Formable Stay-Put Application T321, T316L See page 14	0	90 (6)		70 (5)		70 (5)		43 (3)		43 (3)		43 (3)		28 (2)		14 (1)	
	1	900 (62)	-	800 (55)	-	665 (46)	-	380 (26)	-	355 (24)	-	280 (19)	-	264 (18)	-	221 (15)	-
<b>SHS</b> Standard use Industrial applications T316L See page 15	0	305 (21)		145 (10)		102 (7)		44 (3)		44 (3)		36 (2.5)		36 (2.5)		23 (1.6)	
	1	1450 (100)	4.0 (100)	1305 (90)	6.0 (150)	1160 (80)	8.0 (200)	928 (64)	8.0 (200)	725 (50)	8.0 (200)	580 (40)	10.0 (250)	435 (30)	10.0 (250)	406 (28)	14.0 (350)
<b>SHP</b> Industrial Gas Application T316L See page 16	1	2610 (180)		2102 (145)		2030 (140)		1232 (85)		1131 (78)	8.46 (215)	942 (65)		884 (61)	11.02 (280)	797 (55)	
	2	3697 (255)	4.33 (110)	3233.5 (195)	5.91 (150)	2682 (185)	6.50 (165)	1812 (125)	8.86 (225)	1798 (124)	10.24 (260)	1667 (115)	11.81 (300)	1305 (90)	13.39 (340)	1131 (78)	15.35 (390)
<b>SHG</b> Gas Application High-Pressure Clean Gases T316L See page 17	1	3625 (250)		2175 (150)		2175 (150)		1638* (113)		-		-		-		-	
	2	6090 (420)	7.5 (190)	3540 (244)	9.8 (250)	3625 (225)	11.8 (300)	2726* (113)	13.8* (350)	-		-		-		-	

\* Inside diameter for these hose parameters is 16mm



# HAM-LET Hoses Quick Selection Guide (cont.)

Inside Diameter inch (mm)																	
Hose Series	Number of Braids	1/8 (6.35)		1/4 (6.35)		3/8 (9.53)		1/2 (12.70)		3/4 (19.05)		1 (25.40)		1 1/2 (38.10)		2 (50.80)	
		Working Pressure psi (bar)	Dynamic Bend Radius inch (mm)	Working Pressure psi (bar)	Dynamic Bend Radius inch (mm)	Working Pressure psi (bar)	Dynamic Bend Radius inch (mm)	Working Pressure psi (bar)	Dynamic Bend Radius inch (mm)	Working Pressure psi (bar)	Dynamic Bend Radius inch (mm)	Working Pressure psi (bar)	Dynamic Bend Radius inch (mm)	Working Pressure psi (bar)	Dynamic Bend Radius inch (mm)	Working Pressure psi (bar)	Dynamic Bend Radius inch (mm)
<b>PTFE CORE</b>																	
<b>THT</b> Smooth core See page 27	1	3750 (258)	1.5 (38)	3200 (221)	3.0 (76)	2500 (172)	5.0 (127)	2000 (138)	6.5 (165)	1000 (69)	9.0 (229)	1000 (69)	12.0 (305)	-	-	-	-
<b>THS</b> Silicon covered Smooth core See page 27	1	3750 (258)	1.5 (38)	3200 (221)	3.0 (76)	2500 (172)	5.0 (127)	2000 (138)	6.5 (165)	1000 (69)	9.0 (229)	1000 (69)	12.0 (305)	-	-	-	-
<b>THC</b> Convuluted core See page 28	1	-	-	2500 (172)	0.7 (18)	2000 (136)	0.8 (20)	1500 (103)	1.0 (25)	1100 (76)	2.5 (64)	750 (52)	3.5 (89)	700 (48)	6.0 (152)	525 (36)	7.9 (200)
<b>THB</b> Fiberglass braid See page 28	1	-	-	800 (55)	2.8 (70)	800 (55)	3.3 (83)	800 (55)	5.3 (133)	400 (27)	6.5 (165)	-	-	-	-	-	-
<b>THN</b> Convuluted Insulated PTFE Core with Aramid Braid See page 29	1	-	-	-	-	1250 (86)	2.5 (63.5)	1000 (69)	3.5 (88.9)	500 (35)	4.5 (114.3)	-	-	-	-	-	-
<b>THP</b> Red Silicon Covered Smooth Core See page 29	1	-	-	3000 (207)	2.0 (51)	2500 (172)	4.0 (102)	2000 (138)	5.2 (132)	-	-	-	-	-	-	-	-
<b>THR</b> Fiberglass braid + SS See page 30	1	-	-	3500 (241)	-	3000 (207)	4.0 (102)	1800 (124)	5.5 (140)	1000 (69)	-	1000 (69)	11.5 (292)	-	-	-	-
<b>NYLON HOSES</b>																	
<b>NHG</b> CNG gas application See page 38	-	5000 (345)	1.8 (45)	5000 (345)	3.0 (75)	5000 (345)	3.7 (95)	5000 (345)	7.3 (185)	5000 (345)	9.1 (230)	-	-	-	-	-	-
<b>NHT</b> Nylon reinforced SAE 100R7 See page 39	-	2900 (200)	1.4 (35)	2538 (175)	2.2 (55)	2030 (140)	3.0 (75)	1305 (90)	5.7 (145)	1015 (70)	7.9 (200)	-	-	-	-	-	-
<b>NHT</b> -C – NHT Conductive option See page 39	-	3306 (228)	1.6 (40)	3306 (228)	2.4 (60)	2030 (140)	3.0 (75)	1305 (90)	5.7 (145)	1015 (70)	7.9 (200)	-	-	-	-	-	-
<b>NHP</b> Nylon reinforced SAE 100R8 See page 40	-	5076 (350)	2.0 (50)	4061 (280)	2.8 (70)	3553 (245)	3.7 (95)	2393 (165)	5.9 (150)	2103 (145)	7.9 (200)	-	-	-	-	-	-
<b>NHP</b> -C – NHP Conductive option See page 40	-	5076 (350)	2.0 (50)	4061 (280)	2.8 (70)	3553 (245)	3.7 (95)	-	-	-	-	-	-	-	-	-	-
<b>RUBBER HOSES</b>																	
<b>RHG</b> Designed to use with HAM-LET HOSE END™ See page 34	1	300 (20.7)	2.6 (65)	300 (20.7)	3.0 (75)	300 (20.7)	5.1 (130)	300 (20.7)	7.1 (180)	300 (20.7)	8.0 (203)	-	-	-	-	-	-

# HAM-LET Hoses End Connections Selection

End Connection Type	End Connection Size	Metal Hoses - Series SHF / SHU / SHV / SHE / SHH / SHJ / SHS / SHG I.D. inch (mm)								PTFE Hoses - Series THT / THS / THC / THL / THB / THR (○), Rubber Hose RHG (◇), Nylon Hose NHG / NHT / NHP (□) I.D. inch (mm)						
		1/4 (6.35)	3/8 (9.53)	1/2 (12.70)	3/4 (19.05)	1 (25.40)	1 1/4 (31.75)	1 1/2 (38.10)	2 (50.80)	1/4 (6.35)	3/8 (9.53)	1/2 (12.70)	3/4 (19.05)	1 (25.40)	1 1/2 (38.10)	2 (50.80)
LET-LOK®	1/4"	○	○							○◇□						
	3/8"	○	○	○							○◇□					
	1/2"	○		○	○	○						○◇□				
	3/4"				○	○						○	○◇□			
	1"					○								○◇□		
	1 1/4"						○									
	1 1/2"							○							○	
	2"								○							○
	6mm	○									○◇□					
	8mm	○									○◇□	○				
	10mm		○			○						○◇□				
	12mm		○	○	○	○						○	○◇□			
	18mm				○								○◇□			
25mm					○								○◇□			
38mm								○						○		
Tube Adapter (11/4-2 are preswaged)	1/4"	○	○							○◇□	◇					
	3/8"	○	○	○						○	○◇□	○◇				
	1/2"			○							○◇	○◇□	◇			
	3/4"				○	○						○◇	○◇□	○◇		
	1"				○	○						○	○	○◇□		
	1 1/4"						○									
	1 1/2"							○							○	
	2"								○							○
	6mm	○	○								○◇□		○			
	8mm	○	○	○							○◇□	◇				
	10mm	○	○	○								○◇□				
	12mm			○								◇	○◇□			
	18mm				○								○	○◇□		
25mm					○								○◇□			
38mm								○						○		
50mm									○						○	
ONE-LOK®	1/4"	○														
	3/8"	○	○													
	1/2"			○												
	6mm	○														
	8mm	○														
	10mm		○													
UH Line (for vacuum only)	1/4"	○														
	3/8"	○	○													
	1/2"			○												
	3/4"				○											
Male NPT	1/4"	○	○	○				○		○◇□	○◇	○				
	3/8"	○	○	○						◇	○◇□	○◇□				
	1/2"	○	○	○	○						◇	○◇□	○◇			
	3/4"				○	○						◇	○◇□	○		
	1"				○	○	○							○◇□		
	1 1/4"						○									
	1 1/2"							○							○	
	2"								○							○

# HAM-LET Hoses End Connections Selection (cont.)

End Connection Type	End Connection Size	Metal Hoses - Series SHF / SHU / SHV / SHE / SHH I.D. inch (mm)								PTFE Hoses - Series THT / THS / THC / THL / THB / THR (○), Rubber Hose RHG (◇), Nylon Hose NHG / NHT / NHP (□) I.D. inch (mm)							
		1/4 (6.35)	3/8 (9.53)	1/2 (12.70)	3/4 (19.05)	1 (25.40)	1 1/4 (31.75)	1 1/2 (38.10)	2 (50.80)	1/4 (6.35)	3/8 (9.53)	1/2 (12.70)	3/4 (19.05)	1 (25.40)	1 1/2 (38.10)	2 (50.80)	
Male BSPP	1/4"	○								○◇□							
	3/8"		○								○◇□						
	1/2"			○								○◇□					
	3/4"				○								○◇□				
	1"					○								○◇□			
	1 1/4"						○								○◇□		
Female NPT	1/4"	○								○◇□	○						
	3/8"	○	○								○◇□						
	1/2"	○		○	○							○◇□					
	3/4"				○								○◇□				
	1"					○								○◇□			
	1 1/2"							○							○		
Female BSPP	1/4"	○								○◇□							
	3/8"		○								○◇□						
	1/2"			○								○◇□					
	3/4"												○◇□				
	1"													○◇□			
	1 1/2"								○						○		
Butt Weld adapter	1/4"	○		○						○◇□							
	3/8"	○	○								○◇□						
	1/2"	○		○								○◇□					
	3/4"				○	○							○◇□	○			
	1"					○	○		○					○◇□			
	1 1/4"							○									
Male Face Seal Swivel	1/4"	○								○◇□							
	1/2"	○	○	○								○◇□					
	3/4"				○								○◇□				
	1"					○								○◇□			
	Female Face Seal Swivel	1/4"	○								○◇□						
		1/2"	○	○	○								○◇□				
3/4"					○								○◇□				
1"						○		○						○◇□			
Male JIC 37° Flare	1/4"	○								○◇□							
	3/8"		○								○◇□						
	1/2"			○								○◇□					
	3/4"				○								○◇□				
	1"					○								○◇□			
	1 1/4"							○							○◇□		
Female JIC 37° Flare	1/4"	○								○◇□							
	3/8"		○								○◇□						
	1/2"			○								○◇□					
	3/4"				○								○◇□				
Sanitary Flange	1/2"			○								○◇□					
	3/4"				○								○◇□				
	1"					○								○◇□			
	1-1/2"							○							○		
2"															○		





# HAM-LET METAL HOSES

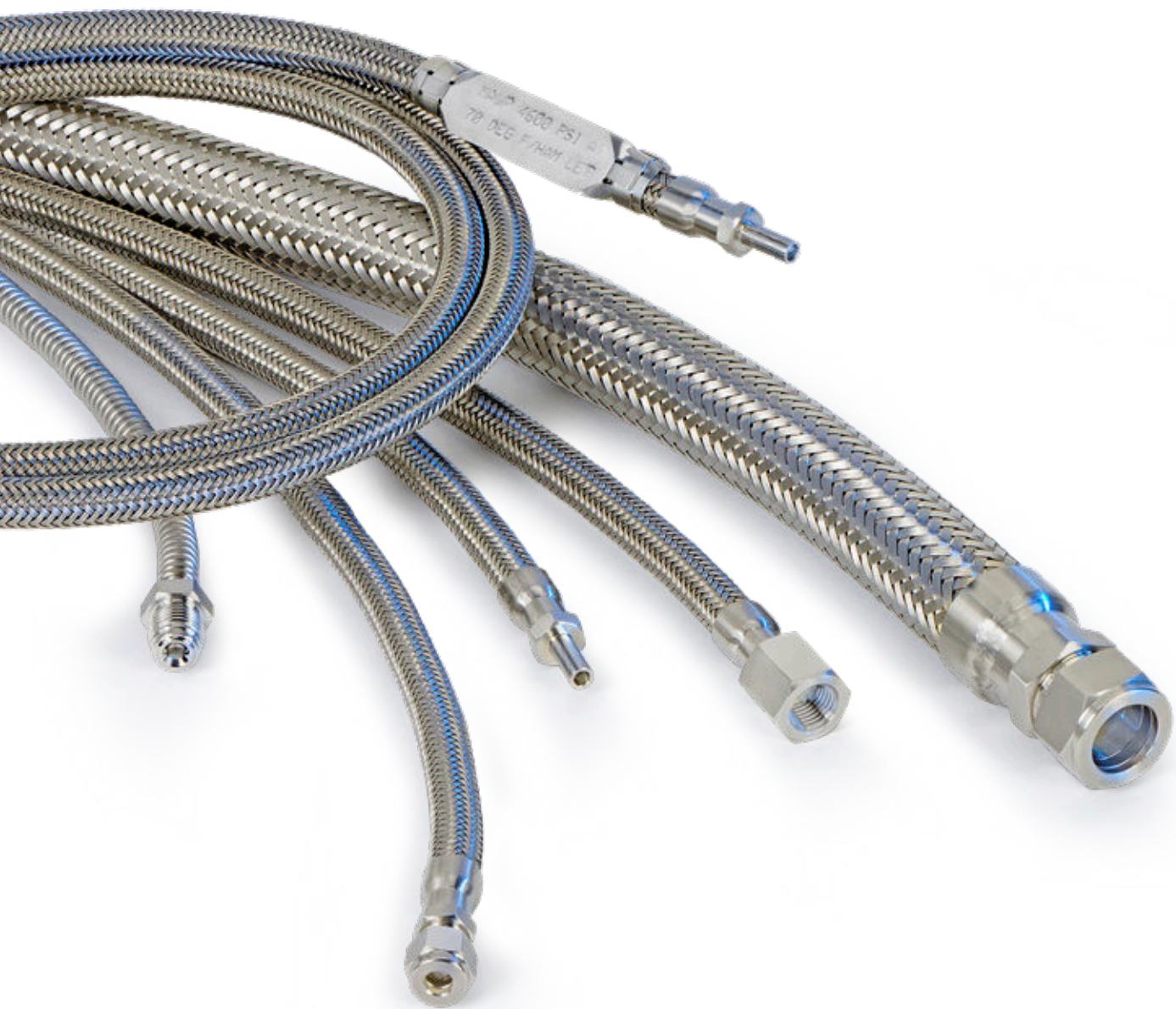

# HAM-LET Metal Hoses

## General

The HAM-LET Metal Hoses are top quality all stainless steel factory welded assemblies that are manufactured and tested to meet industry demands and regulation for chemical, process, Oil & Gas, Power generation, Pumps & Vacuum, instrumentation, gases and semiconductors manufacturing and machinery.

The HAM-LET Metal Hose assemblies are constructed from only best materials and components and by the most advanced corrugating and welding technologies for leak free durable performances.

HAM-LET Metal Hoses are the best solution for flexible connection of Gas & Liquid lines where vibrating, moving parts and installations involve high temperatures, chemicals and aggressive media, high pressures and full vacuum.

## Features

- All stainless steel assembly
- LET-LOK®, ONE-LOK®, Face seal, UH Line end fittings among others
- ID sizes: 1/4" up to 2"
- Pressure rating: Vacuum to 6,000 psi (414 bar), 4 to 1 safety factor
- Working temperatures -425°F (-254°C) up to 1300°F (705°C)
- Hydroformed or spirally-welded corrugated inner hose
- Machine braided (braid is woven directly on inner hose)
- Maximum Working Pressure marked on metal tag as standard.
- Manufactured in accordance to:
  - NAHAD – Corrugated Metal Hose Assembly specification guidelines
  - DIN ISO 10380 for designated items
- Pipework – Corrugated metal hoses and hose assemblies.

## Metal Hoses Manufacturing Process

### Corrugated Tube

A high quality stainless steel thin walled tube is specifically manufactured. As a second stage, corrugations are formed into the tube to make it flexible. Corrugations are formed into the tube hydraulically using a unique process called "Hydroforming" (rather than the commonly used mechanical method).

Hydroforming process evenly distributes stresses on the tube wall. This unique method maintains wall thickness, reduces concentrated residual stress, and minimizes work hardening, resulting in enhanced flexibility and prolong cycle life.

### Hydroformed

Evenly distributed stresses

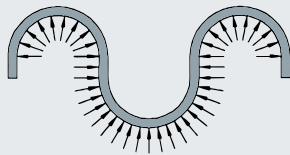

### Mechanically Formed

Concentrated stresses

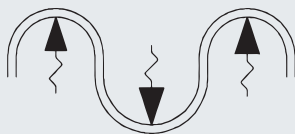

Hydroforming is a clean process, using water to form the hose, while most other processes require lubrication.

**Hydroforming** - HAM-LET utilizes a proprietary method of hydroforming in which corrugations are formed by expanding a section of stainless steel tube with high pressure water from inside the tube, while simultaneously feeding the tube axially into the process. Hydroforming is a clean, gentle process that enhances flexibility and cycle life, maintains wall thickness, reduces concentrated residual stress, and minimizes work hardening of materials.

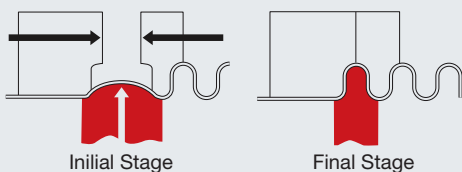

### Braid

As a third (optional) stage, stainless steel wire is braided over the hose enabling the corrugated hose the ability to withstand higher pressures. Hoses may be single braided (one layer of braid) or



double braided (two layers of braid) to achieve even greater working pressures.

**Braiding Superiority** - A High Percentage Braid Coverage - highest percentage of braid coverage, yielding better cycle life and protection against damage to the hose.

**Machine Braided** - The braid is woven directly onto the hose, ensuring that the braid fits tightly against the hose, preventing potential hose deformation or squirm. Machine braided hose also offers repeatable performance and longer cycle life.

### Assembly



Combining top quality hose with top quality fittings together with a specialized welding, brazing, joining, fabrication procedures, and severe testing assures compatibility, integrity and serviceability of metal hose assemblies in even the most

extreme applications and demanding industries.

Standard assembly process consists of:

- Cutting the hose and braid through a hose corrugation valley.
- Installing a braid collar over each end of the hose.
- Trimming of any excess braid.
- "Cap" welding the hose, braid, and braid collar together.
- Cleaning the cap weld surface.
- Placement and alignment of a fitting on the cap weld.
- "Attachment" welding the fitting to the cap weld.
- The assembled hose is tested, cleaned, marked and packed as required.

## Metal Hose Selecting Considerations:

When selecting a Flexible Metal Hose, consider the following 5 variables:

### 1. Temperature

As the media or ambient temperature increases, the hose working pressure decreases. With your selected hose construction materials, go to “Working Pressure De-Rating Factor” table and match the alloy of the hose and braid with the highest temperature to which they will be exposed (either internally or externally) to obtain the proper de-rating factors. Then multiply the hose maximum working pressure by the most limiting temperature de-rating factor, Maximum Working Pressures marked on metal tag as standard.

### 2. Dynamic Pressure

Pulsating, surge or shock pressures, like those encountered by quick opening or closing valves, can inflict severe damage on a hose. If your application entails pulsating pressures, the working pressure should be de-rated by 1/2. If your application entails shock pressures, de-rate the stated working pressure to 1/6 of its value.

Example : 1/4” hose - T316L stainless steel hose and T304 stainless steel braid at 500°F with the shock pressures:  
 Catalog Maximum Working Pressure = 1800 psi  
 Temperature De-rating Factor at 500°F = 0.86  
 Pressure De-rating Factor = 1/6 Maximum Application Working Actual allowable working pressure = 1800 PSI x 0.86 x 1/6 = 258 psi

### 3. Flexibility

Verify that the minimum bend radius of the hose is less than the bend radius required.  
 Larger installation radius reduces fatigue on the hose for a longer assembly life.

### 4. Chemical Compatibility

The material that you choose for the hose and braid must be compatible with the media that will flow through the hose, as well as the environment in which the hose is installed. When determining chemical compatibility, be sure that you know the temperature and concentration of the chemical or chemicals. Although there are many resources to confirm chemical compatibility, two of the industry standards that you may find useful are the National Association of Corrosion Engineers (NACE) and the Compass Corrosion Guides.

### 5. Accessories

Optional accessories available include spring guards, protective covers, insulating covers and protective armor.

## Cleaning & Packing

The hydroforming hose manufacturing process yields a very clean product.

Clean and Degrease to CGA G-4.1 “Oxygen Clean” is available. Ultrasonic Cleaning for Pharmaceutical application is available. Each hose is packed in a plastic bag, end connections are capped.

## Testing

All HAM-LET hose assemblies are 100% tested. Helium leak testing up to 1x10<sup>-9</sup> Std. CC/Sec is available. Other test such as Hydrostatic testing, Nitrogen/Helium bubble test are available.

\*Helium leak test is available to hoses up to 100' (30m)

## Working pressure de-rating factor:

Temp. in		304	304L	316	316L	321	C276
Degrees F	Degrees C						
70	20	1.00	1.00	1.00	1.00	1.00	1.00
100	40	1.00	1.00	1.00	1.00	1.00	1.00
200	95	1.00	1.00	1.00	1.00	1.00	1.00
300	150	1.00	1.00	1.00	1.00	1.00	1.00
400	205	0.94	0.93	0.97	0.93	1.00	1.00
500	260	0.88	0.86	0.90	0.86	0.96	0.99
600	315	0.82	0.81	0.85	0.81	0.91	0.93
650	345	0.81	0.79	0.84	0.79	0.89	0.90
700	370	0.80	0.77	0.82	0.77	0.87	0.88
750	400	0.78	0.75	0.81	0.75	0.86	0.86
800	430	0.76	0.74	0.80	0.74	0.84	0.84
850	455	0.75	0.72	0.79	0.72	0.84	0.83
900	480	0.73	0.71	0.78	0.71	0.83	0.82
950	510	0.72	0.69	0.77	0.69	0.81	0.81
1000	540	0.69	0.67	0.77	0.67	0.81	0.80
1050	565	0.61	0.65	0.73	0.65	0.70	0.68
1100	595	0.49	0.62	0.62	0.61	0.55	0.55
1150	620	0.39	0.53	0.49	0.52	0.41	0.47
1200	650	0.30	0.38	0.37	0.38	0.32	0.36
1250	675	0.24	0.28	0.28	0.28	0.25	0.29
1300	705		0.21	0.21	0.21		

## General

The SHF – General Use hose series is the basic hose for industrial applications of gas & liquid lines with high temperatures, corrosive media and harsh environment.

## Features

- Braided, double braided or unbraided corrugated tube assembly
- Core tube is made of 316L stainless steel, 321 stainless steel core tube is available.
- Braid is made of 304 stainless steel, 316 stainless steel braid is available.
- Annular Hydroformed corrugation
- Tube ID from ¼” to 2”
- Max. working pressure 2700psi (186bar)
- Min. static bend radius for braided hose 1.0inch (25mm)
- Min. dynamic bend radius for braided hose 4.5inch (114mm)
- Full range of end connections

## SHF Series - General Use

Inside Diameter		Number of Braids	Outside Diameter		Static Minimum Bend Radius		Dynamic Minimum Bend Radius		Maximum Working Pressure		Burst Pressure		Weight Per Foot	Weight Per Meter
inch	mm		inch	mm	inch	mm	inch	mm	psi	bar	psi	bar	lbs	kg
1/4	6.35	0	0.41	10.4	1.0	25	4.5	114	90	6	n/a	n/a	0.04	0.06
		1	0.47	11.9					1,800	124	7,233	499	0.11	0.16
		2	0.53	13.5					2,700	186	9,100	627	0.18	0.27
3/8	9.53	0	0.65	16.5	1.2	30	5.0	127	70	5	n/a	n/a	0.10	0.15
		1	0.71	18.0					1,558	107	6,230	430	0.20	0.30
		2	0.77	19.6					2,336	161	9,345	644	0.30	0.45
1/2	12.70	0	0.77	19.6	1.5	38	5.5	140	70	5	n/a	n/a	0.11	0.16
		1	0.83	21.1					1,186	82	4,743	327	0.22	0.33
		2	0.89	22.6					1,779	123	7,115	491	0.33	0.49
5/8	15.88	0	0.96	24.4	1.8	46	7.0	178	57	4	n/a	n/a	0.17	0.25
		1	1.02	25.9					1,205	83	4,820	332	0.33	0.49
		2	1.08	27.4					1,808	125	7,230	498	0.49	0.73
3/4	19.05	0	1.16	29.5	2.1	53	8.0	203	43	3	n/a	n/a	0.19	0.28
		1	1.22	31.0					898	62	3,591	248	0.37	0.55
		2	1.28	32.5					1,347	93	5,387	371	0.55	0.82
1	25.40	0	1.47	37.3	2.7	69	9.0	229	43	3	n/a	n/a	0.26	0.39
		1	1.53	38.9					718	50	2,872	198	0.50	0.74
		2	1.59	40.4					1,077	74	4,308	297	0.74	1.10
1 1/4	31.75	0	1.75	44.5	3.1	79	10.0	254	43	3	n/a	n/a	0.29	0.43
		1	1.83	46.5					645	44	2,581	178	0.61	0.91
		2	1.91	48.5					968	67	3,872	267	0.93	1.38
1 1/2	38.10	0	2.08	52.8	3.9	99	11.0	279	28	2	n/a	n/a	0.47	0.70
		1	2.16	54.9					531	37	2,125	147	0.85	1.26
		2	2.24	56.9					797	55	3,188	220	1.23	1.83
2	50.80	0	2.61	66.3	5.1	130	13.0	330	14	1	n/a	n/a	0.59	0.88
		1	2.69	68.3					449	31	1,797	124	1.11	1.65
		2	2.77	70.4					674	46	2,696	186	1.63	2.43



## Materials of Construction

Part	Material
Tube	SS 316L / SS 321
Braid	SS 304 / SS 316
End Connections	SS 316L



## General

The SHE – Extra flexible hose series provides improved flexibility for smaller minimal static and dynamic bend radii. The extra flexibility is provided by denser corrugations while maintaining the same pressure rating.

## Features

- Braided, double braided or unbraided corrugated tube assembly
- Core tube is made of 316L stainless steel, 321 stainless steel core tube is available.
- Braid is made of 304 stainless steel, 316 stainless steel braid is available.
- Annular Hydroformed corrugation
- Tube ID from ¼” to 2”
- Max. working pressure 2700psi (186bar)
- Min. static bend radius for braided hose 0.9inch (23mm)
- Min. dynamic bend radius for braided hose 3.7inch (94mm)
- Full range of end connections

## SHE Series - Extra Flexible

Inside Diameter		Number of Braids (#)	Outside Diameter		Static Minimum Bend Radius		Dynamic Minimum Bend Radius		Maximum Working Pressure		Burst Pressure		Weight Per Foot	Weight Per Meter
inch	mm		inch	mm	inch	mm	inch	mm	psi	bar	psi	bar	lbs	kg
1/4	6.35	0	0.42	10.7	0.9	23	3.7	94	90	6	n/a	n/a	0.07	0.10
		1	0.48	12.2					1,800	124	7,233	499	0.14	0.21
		2	0.54	13.7					2,700	186	9,100	627	0.20	0.30
3/8	9.53	0	0.65	16.5	1.0	25	4.0	102	70	5	n/a	n/a	0.15	0.22
		1	0.71	18.0					1,558	107	6,230	430	0.25	0.37
		2	0.77	19.6					2,336	161	9,345	644	0.36	0.54
1/2	12.70	0	0.77	19.6	1.2	30	4.4	112	70	5	n/a	n/a	0.18	0.27
		1	0.83	21.1					1,186	82	4,743	327	0.32	0.48
		2	0.89	22.6					1,779	123	7,115	491	0.47	0.70
5/8	15.88	0	0.96	24.4	1.4	36	5.6	142	57	4	n/a	n/a	0.19	0.28
		1	1.02	25.9					1,205	83	4,820	332	0.37	0.55
		2	1.08	27.4					1,808	125	7,230	498	0.54	0.80
3/4	19.05	0	1.16	29.5	1.7	43	6.4	163	43	3	n/a	n/a	0.31	0.46
		1	1.22	31.0					898	62	3,591	248	0.53	0.79
		2	1.28	32.5					1,347	93	5,387	371	0.74	1.10
1	25.40	0	1.47	37.3	2.1	53	7.1	180	43	3	n/a	n/a	0.41	0.61
		1	1.53	38.9					718	50	2,872	198	0.76	1.13
		2	1.63	41.4					1,077	74	4,308	297	1.11	1.65
1 1/4	31.75	0	1.75	44.5	2.5	64	7.9	201	43	3	n/a	n/a	0.63	0.94
		1	1.83	46.5					645	44	2,581	178	1.00	1.49
		2	1.91	48.5					968	67	3,872	267	1.37	2.04
1 1/2	38.10	0	2.08	52.8	3.1	79	8.7	221	28	2	n/a	n/a	0.70	1.04
		1	2.16	54.9					531	37	2,125	147	1.16	1.73
		2	2.24	56.9					797	55	3,188	220	1.63	2.43
2	50.80	0	2.61	66.3	4	102	10.3	262	14	1	n/a	n/a	0.88	1.31
		1	2.69	68.3					449	31	1,797	124	1.44	2.14
		2	2.77	70.4					674	46	2,696	186	1.99	2.96



## Materials of Construction

Part	Material
Tube	SS 316L / SS 321
Braid	SS 304 / SS 316
End Connections	SS 316L

## General

The SHJ - Higher-pressure more flexible hose series is hydroformed annular corrugated metal hose, made from heavy-wall stainless steel.

SHJ offers flexibility and dependability when higher pressures are a factor.

## Features

- Braided, double braided or unbraided corrugated tube assembly
- Core tube is made of 316L stainless steel, 321 stainless steel core tube is available.
- Braid is made of 304 stainless steel, 316 stainless steel braid is available.
- Annular Hydroformed corrugation
- Tube ID 1/4" up to 2"
- Max. working pressure 4000psi (276 bar), 4 to 1 safety rate factor
- Min. static bend radius for braided hose 1.0 inch (25mm)
- Min. dynamic bend radius for braided hose 5.5inch (140mm)
- Full range of end connections

## SHJ Series - Higher-pressure more flexible

Inside Diameter		Number of braids (#)	Outside Diameter		Static Minimum Bend Radius		Dynamic Minimum Bend Radius		Maximum Working Pressure		Burst pressure		Weight per foot	Weight per Meter
Inch	mm		Inch	mm	Inch	mm	Inch	mm	psi	bar	psi	bar	lbs	kg
1/4	6.35	0	0.42	10.7	1.0	25	5.5	140	450	31	N/A	N/A	0.08	0.12
		1	0.48	12.2					3,000	207	12,000	827	0.15	0.22
		2	0.54	13.7					4,000	276	16,000	1,103	0.22	0.33
1/2	12.7	0	0.77	19.6	2.5	64	10.0	254	400	28	N/A	N/A	0.24	0.36
		1	0.85	21.6					2,400	165	9,600	662	0.40	0.6
		2	0.93	23.6					3,200	221	12,800	883	0.57	0.85
3/4	19.05	0	1.13	28.7	4.0	102	8.0	203	220	15	N/A	N/A	0.41	0.61
		1	1.19	30.2					1,100	76	4,430	305	0.58	0.86
		2	1.25	31.8					1,650	114	6,696	462	0.76	1.13
1	24.4	0	1.43	36.3	5.0	127	9.0	229	190	13	N/A	N/A	0.52	0.77
		1	1.49	37.8					1,000	69	4,187	289	0.76	1.13
		2	1.55	39.4					1,400	97	5,837	402	0.99	1.47
1 1/4	24.4	0	1.74	44.2	6.5	165	12.0	305	200	14	N/A	N/A	0.76	1.13
		1	1.82	46.2					900	62	3,758	259	1.13	1.68
		2	1.90	48.3					1,350	93	5,494	379	1.50	2.23
1 1/2	24.4	0	2.10	53.3	7.5	191	13.0	330	90	6	N/A	N/A	1.13	1.68
		1	2.18	55.4					750	52	3,070	212	1.54	2.29
		2	2.26	57.4					1,200	83	4,842	334	1.96	2.92
2	24.4	0	2.55	64.8	9.0	229	15.0	381	105	7	N/A	N/A	1.10	1.64
		1	2.68	68.1					800	55	3,304	228	2.29	3.41
		2	2.80	71.1					1,150	79	4,738	327	3.47	5.16



### Materials of Construction

Part	Material
Tube	SS 316L / SS 321
Braid	SS 304 / SS 316
End Connections	SS 316L

## General

The SHU – Ultra high pressure hose series is hydroformed annular, heavy-wall corrugated metal hose, specifically designed for ULTRA-high-pressure applications.

The SHU hoses offer superior flexibility and are made from heavy-wall 321 stainless steel.

## Features

- Braided, double braided or unbraided corrugated tube assembly
- Core tube is made of 321 stainless steel, 316L stainless steel core tube is available.
- Braid is made of 321 stainless steel.
- Annular Hydroformed corrugation
- Tube ID 1/4", 3/4" up to 2"
- Max. working pressure 6000psi (414bar), 4 to 1 safety rate factor
- Min. static bend radius for braided hose 1.5 inch (38mm)
- Min. dynamic bend radius for braided hose 4.5inch (114mm)
- Full range of end connections

## SHU Series - Ultra High Pressure

Inside Diameter		Number of Braids (#)	Outside Diameter		Static Minimum Bend Radius		Dynamic Minimum Bend Radius		Maximum Working Pressure		Burst Pressure		Weight Per Foot	Weight Per Meter
inch	mm		inch	mm	inch	mm	inch	mm	psi	bar	psi	bar	lbs	kg
1/4	6.35	0	0.43	10.9	0.5	13	4.5	114	500	34	n/a	n/a	0.15	0.22
		1	0.56	14.1	1.5	38			5,000	345	20,000	1,379	0.32	0.48
		2	0.68	17.3	1.5	38			6,000	414	24,000	1,655	0.49	0.73
3/8	9.53	0	0.67	17.03	1.5	38.13	7.0	178	400	28	1,600	110	0.18	0.27
		1	0.80	20.21	2.5	63.55			3,500	241	14,000	965	0.46	0.68
		2	0.92	23.39	2.5	63.55			5,000	345	20,000	1,379	0.77	1.14
1/2	12.70	0	0.78	19.9	2.0	51	8.5	203	200	14	n/a	n/a	0.43	0.64
		1	0.88	22.5	3.0	76			2,700	186	10,800	744	0.64	0.95
		2	0.98	25.0	3.0	76			4,500	310	18,000	1,240	0.85	1.26
3/4	19.05	0	1.15	29.2	2.5	64	4.5	114	250	17	n/a	n/a	0.63	0.94
		1	1.28	32.5	4.0	102	10.0	254	2,650	183	10,669	736	1.09	1.62
		2	1.40	35.6	4.0	102	10.0	254	3,600	248	14,521	1,001	1.58	2.35
1	25.40	0	1.45	36.8	3.25	83	7.0	178	180	12	n/a	n/a	0.84	1.25
		1	1.57	39.9	5.0	127	11.0	279	2,500	172	10,000	689	1.53	2.28
		2	1.70	43.2	5.0	127	11.0	279	3,000	207	12,083	833	2.25	3.35
1 1/4	31.75	0	1.75	44.5	5.0	127	9.5	241	190	13	n/a	n/a	1.32	1.96
		1	1.88	47.8	6.5	165	12.5	318	1,775	122	7,119	491	2.09	3.11
		2	2.00	50.8	6.5	165	12.5	318	2,600	179	10,400	717	2.88	4.29
		3	2.13	54.1	7.0	178	14.0	356	3,000	207	12,082	833	3.71	5.52
1 1/2	38.10	0	2.11	53.6	6.0	152	11.5	292	110	8	n/a	n/a	1.75	2.60
		1	2.23	56.6	7.5	191	13.0	330	1,450	100	5,800	400	2.64	3.93
		2	2.36	59.9	7.5	191	13.0	330	2,200	152	8,892	613	3.57	5.31
2	50.80	0	2.57	65.3	7.5	191	12.0	305	100	7	n/a	n/a	2.04	3.04
		1	2.70	68.6	9.0	229	14.0	356	1,100	76	4,415	304	3.23	4.81
		2	2.82	71.6	9.0	229	14.0	356	1,675	115	6,710	463	4.45	6.62



### Materials of Construction

Part	Material
Tube	SS 321 / SS 316L
Braid	SS 321
End Connections	SS 316L

## General

The SHV – Formable hoses series are hand formable tubes that keep their formation. These hoses are designed to bend and stay in one position, providing a stress-free connection between piping systems .

SHV hose can be compressed or stretched to fit into an exact space in the system

## Features

- Braided or unbraided corrugated tube assembly.
- Core tube is made of 321 stainless steel, 316L stainless steel core tube is available.
- Braid is made of 304 stainless steel
- Annular Hydroformed corrugation
- Tube ID 1/4", 3/8", 1/2"
- Max. working pressure 900psi (62bar)
- Min. static bend radius for braided hose 1.0inch (25mm)
- Full range of end connections

## SHV Series - Formable

Inside Diameter		Number of Braids	Outside Diameter		Static Minimum Bend Radius		Dynamic Minimum Bend Radius		Maximum Working Pressure		Burst Pressure		Weight Per Foot	Weight Per Meter
inch	mm		inch	mm	inch	mm	inch	mm	psi	bar	psi	bar	lbs	kg
1/4	6.35	0	0.41	10.4	1.0	25	n/a	n/a	90	6	n/a	n/a	0.04	0.06
		1	0.47	11.9					900	62	3,600	248	0.11	0.16
3/8	9.53	0	0.65	16.5	1.2	30	n/a	n/a	70	5	n/a	n/a	0.10	0.15
		1	0.71	18.0					800	55	3,200	221	0.17	0.25
1/2	12.70	0	0.77	19.6	1.5	38	n/a	n/a	70	5	n/a	n/a	0.11	0.16
		1	0.83	21.1					665	46	2,660	183	0.19	0.28



### Materials of Construction

Part	Material
Tube	SS 321 / SS 316L
Braid	SS 304
End Connections	SS 316L



Formable stay-put hoses



## General

The SHS – Standard Use Hose series is a basic hose for industrial applications of gas & liquid lines with high temperatures, corrosive media and harsh environments.

## Features

- Braided or unbraided corrugated tube assembly
- All stainless steel Assembly
- Annular Hydroformed corrugation
- Tube ID from ¼” to 2”
- Max. working pressure 1740 psi (120 bar)
- Min. static bend radius for braided hose 1.0inch (25mm)
- Min. dynamic bend radius for braided hose 3.0 inch (85 mm)
- Full range of HAM-LET’s end connections
- Manufactured according EN ISO 10380

## SHS Series - Standard

Inside Diameter		Number of Braids	Outside Diameter		Static Minimum Bend Radius		Dynamic Minimum Bend Radius		Maximum Working Pressure		Burst Pressure		Weight Per Foot	Weight Per Meter
inch	mm		inch	mm	inch	mm	inch	mm	psi	bar	psi	bar	lbs	kg
1/4	6.2	0	0.38	9.6	1.0	25	3.35	85	305	21	1218	84	0.12	0.08
		1	0.41	10.5					1,740	120	6,960	480	0.21	0.14
3/8	10.3	0	0.56	14.3	1.5	38	5.51	140	145	10	580	40	0.17	0.11
		1	0.61	15.5					1,233	85	4,930	340	0.29	0.19
1/2	12.2	0	0.66	16.7	1.8	45	5.51	140	102	7	406	28	0.18	0.12
		1	0.70	17.8					1,088	75	4,350	300	0.32	0.21
3/4	20.2	0	1.06	26.8	2.8	70	6.69	170	44	3	174	12	0.39	0.26
		1	1.11	28.3					928	64	3,712	256	0.72	0.48
1	25.4	0	1.27	32.2	3.3	85	7.48	190	44	3	174	12	0.56	0.37
		1	1.32	33.5					725	50	2,900	200	0.98	0.65
1 1/4	34.3	0	1.62	41.1	4.1	105	10.24	260	36	2.5	145	10	0.62	0.41
		1	1.69	42.8					580	40	2,320	160	1.14	0.76
1 1/2	40.1	0	1.95	49.5	5.1	130	11.81	300	36	2.5	145	10	0.80	0.53
		1	2.02	51.2					508	35	2,030	140	1.58	1.05
2	50.3	0	2.37	60.3	6.3	160	12.60	320	23	1.6	92.8	6.4	1.02	0.68
		1	2.44	62					435	30	1740	120	2.16	1.44



### Materials of Construction

Part	Material
Tube	SS 316L
Braid	SS 304
End Connections	SS 316L

## General

The SHP – Industrial Gas Application hose series is made of heavy wall and close pitch, annular corrugation obtained by hydroforming.

Dedicated to transfer chemicals, gases, steam under pressure and in high vacuum conditions.

## Features

- Single or double braided corrugated tube assembly.
- Core tube is made of 316L stainless steel.
- Annular Hydroformed corrugation.
- Tube ID 1/4" up to 2".
- Max. dynamic working pressure 3698psi (255bar).
- Min. static bend radius for braided hose 1.0 inch (25mm).
- Min. dynamic bend radius for braided hose 4.3 inch (110mm).
- Full range of end connections.
- Manufactured according EN ISO 10380.

## SHP Series - Industrial Gas Application

Inside Diameter		Number of Braids (#)	Outside Diameter		Static Minimum Bend Radius		Dynamic Minimum Bend Radius		Maximum Working Pressure (static cond)		Maximum Working Pressure (dynamic cond)		Burst Pressure	
inch	mm		inch	mm	inch	mm	inch	mm	psi	bar	psi	bar	psi	bar
1/4	6	1	0.45	11.4	1.0	25	4.33	110	3,263	225	2,610	180	10,440	720
		2	0.51	13					4,249	293	3,698	255	14,790	1,020
3/8	10	1	0.70	17.8	1.5	38	5.91	150	2,407	166	2,103	145	8,410	580
		2	0.76	19.4					3,234	223	2,828	195	11,310	780
1/2	12	1	0.80	20.2	1.8	45	6.50	165	2,538	175	2,030	140	8,120	560
		2	1.21	30.7					3,089	213	2,683	185	10,730	740
3/4	20	1	1.15	29.1	2.8	70	8.86	225	1,436	99	1,233	85	4,930	340
		2	1.21	30.7					2,132	147	1,813	125	7,250	500
1	25	1	1.50	38	3.3	85	8.46	215	1,320	91	1,131	78	4,524	312
		2	1.57	40					10,24	260	2,059	142	1,798	124
1 1/4	32	1	1.83	46.5	4.1	105	11.81	300	1,131	78	943	65	3,770	260
		2	1.93	49					1,943	134	1,668	115	6,670	460
1 1/2	40	1	2.16	54.9	5.1	130	11.02	280	986	68	885	61	3,538	244
		2	2.26	57.4					13.39	340	1,508	104	1,305	90
2	50	1	2.65	67.3	6.3	160	15.35	390	899	62	798	55	3,190	220
		2	2.75	69.8					1,334	92	1,131	78	4,524	312



### Materials of Construction

Part	Material
Tube	SS 316L / SS321
Braid	SS 304
End Connections	SS 316L

### CGA End connector

End connectors	Gas Types
FA CGA 320	Carbon Dioxide, Methyl Fluoride
FA CGA 350	Arsine, Ethane, Methane, Natural Gas
FA CGA 540	Oxygen
FA CGA 580	Argon, Helium, Krypton, Neon, Nitrogen, Xenon
FA CGA 590	Sulfur Hexafluoride

## General

The SHG – Gas application hose specially designed for high pressure clean gases.  
Gas filling stations and connection between gas cylinders and regulators are good application examples..

## Features

- Braided corrugated tube assembly
- All stainless steel Assembly
- Annular Hydroformed corrugation
- Tube ID from ¼” to ½”
- Max. working pressure 6090psi (420bar)
- Min. static bend radius for braided hose 1.18inch (30mm)
- Min. dynamic bend radius for braided hose 7.48inch (190mm)
- Full range of HAM-LET’s end connections
- Manufactured according EN ISO 10380

## SHG Series - High pressure industrial

Inside Diameter		Number of Braids	Outside Diameter		Static Minimum Bend Radius		Dynamic Minimum Bend Radius		Maximum Working Pressure		Burst Pressure		Weight Per Foot	Weight Per Meter
inch	mm		inch	mm	inch	mm	inch	mm	psi	bar	psi	bar	lbs	kg
1/4	6.35	1	0.48	12.2	1.18	30	7.48	190	3,625	250	14,500	1,000	0.17	0.26
		2	0.57	14.4					6,090	420	24,365	1,680	0.30	0.44
3/8	9.53	1	0.71	18	1.77	45	9.84	250	2,175	150	8,700	600	0.29	0.43
		2	0.79	20.1					3,540	244	14,155	976	0.42	0.63
1/2	12.7	1	0.82	20.8	2.17	55	11.81	300	2,175	150	8,700	600	0.39	0.58
		2	0.9	22.9					3,265	225	13,055	900	0.56	0.84



## Materials of Construction

Part	Material
Tube	SS 316L
Braid	SS 304
End Connections	SS 316L

# Selecting & Installing Metal Hose Assemblies

## When Metal Hose Is A Proper Solution

### 1. Temperature Extremes

Metal Hose is the best solution for extreme hot and cold media or surrounding temperatures.

### 2. Chemical Compatibility

Chemicals and aggressive media or corrosive environments are often better serviced by stainless metal hose.

### 3. Permeation Concerns

Permeation prevention of media into the surrounding atmosphere is best assured by using metal hose.

### 4. Potential for Catastrophic Failure

Potentially catastrophic failure effect of hose may be minimized by using metal hose that tends to develop smaller holes or cracks when failing than other hose types.

### 5. Fire Safety

Maintaining integrity up to 1300°F (705°C) is provided by metal hoses.

### 6. Achieving Full Vacuum

Maintaining shape under full vacuum is better assured by metal hoses.

### 7. Flexibility in Fitting Configuration

Virtually any type of fitting can be assembled with a metal hose to perfectly meet most tubing and fitting systems.

## Hose Assembly

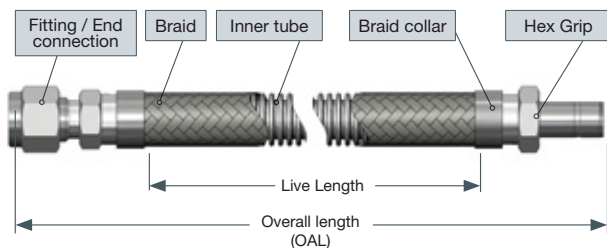

## Thread Allowance

When calculating the overall length (OAL) of a hose assembly that has a pipe thread as one or both end connection(s), consideration must be given to thread engagement.

Example: using the chart below, a hose assembly with a 1" male pipe on one end would have 0.66" added to the OAL to compensate for the length of thread that will be engaged during installation.

Nominal Pipe Size inch	1/4	3/8	1/2	3/4	1	1 1/4	1 1/2	2
Thread Allowance inch (mm) -Dim "A"	0.40 (10)	0.41 (10)	0.53 (13)	0.55 (14)	0.66 (17)	0.68 (17)	0.68 (17)	0.70 (18)

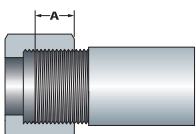

## Length Considerations

To calculate the proper length of a hose assembly, you need to:

- Verify that the installation is properly designed (see Do's & Don'ts herein)
  - Do not torque the hose
  - Do not over-bend the hose
  - Do not compress the hose
- Calculate the live length of the assembly - The live length of the assembly is the amount of active (flexible) hose in an assembly; that is, the hose between the braid collars (see formulas to help calculate live length for a variety of common hose installations herein)
- Calculate the overall length of the assembly - Overall length is equal to the live length plus the lengths of the braid collars and fittings. When adding fitting lengths, be aware that the points from which measurements should be taken vary for different fitting types. When calculating overall length for assemblies with threaded fittings, remember to account for the length of thread that is lost by threading into the mating connection (refer to Thread Allowance chart herein).

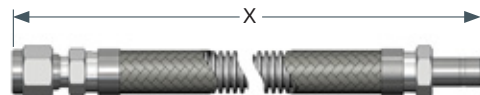

Compression fittings are measured to the end of the fitting

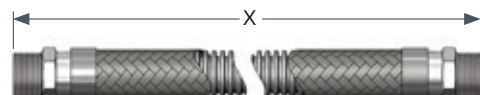

Threaded fittings are measured to the end of the fitting

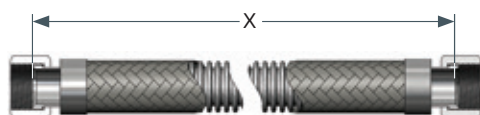

JIC/SAE-type fittings are measured from the seat of the fitting

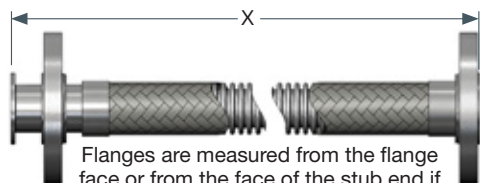

Flanges are measured from the flange face or from the face of the stub end if one is used

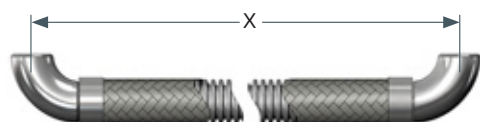

Elbows and other fittings with a radius are measured from the centerline of the fitting



# Selecting & Installing Metal Hose Assemblies

## Live Length Calculations

For the following formulas:

<b>L</b>	Live length of hose (inches/mm)
<b>T</b>	Travel (inches/mm)
<b>S</b>	Hose outside diameter (see product data pages herein)
<b>R</b>	Bend radius, measured to hose center line

Verify that the installed radius is greater than the stated Minimum Bend Radius for the hose at the required working pressure. Verify that the centerline of the hose remains in the same plane during cycling to prevent twisting the assembly.

### Constant Radius Traveling Loop (A-Loop)

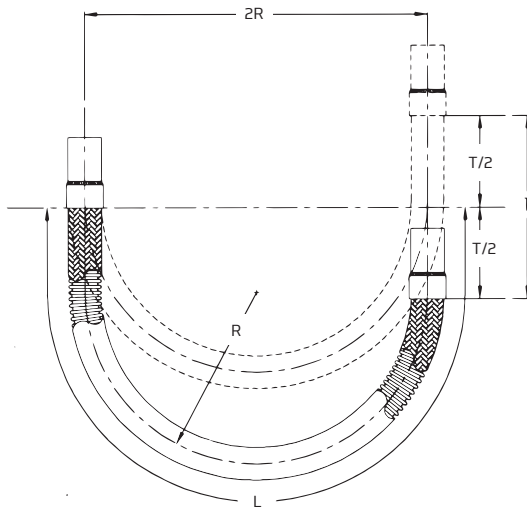

Formula:  $L = 4R + 1/2T$

### Variable Radius Traveling Loop (B-loop)

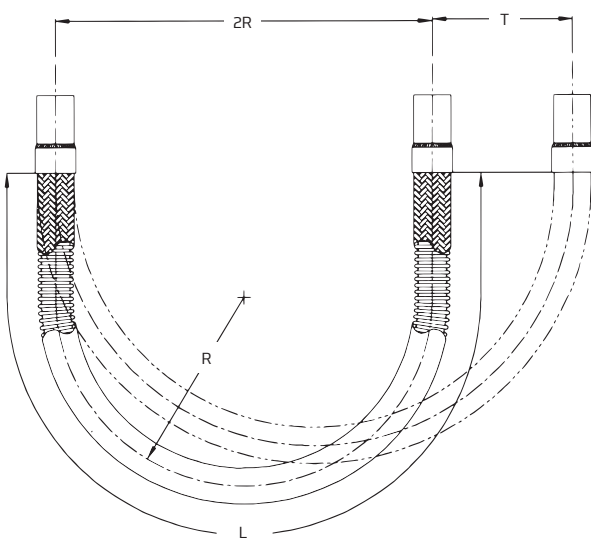

Formula:  $L = 4R + 1.57T$

### Lateral Offset

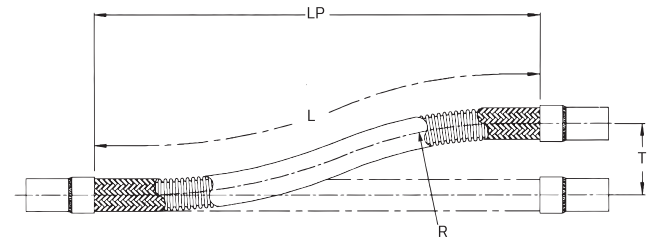

Formula:  $L = \sqrt{20R \times T}$ ,  $L_p = \sqrt{L^2 - T^2}$

**Note 1:** When the offset motion occurs on both sides of the hose centerline, use total travel in the formula

**Note 2:** The offset distance "T" for constant flexing should never exceed 25% of the centerline bend radius

### Angular Deflection

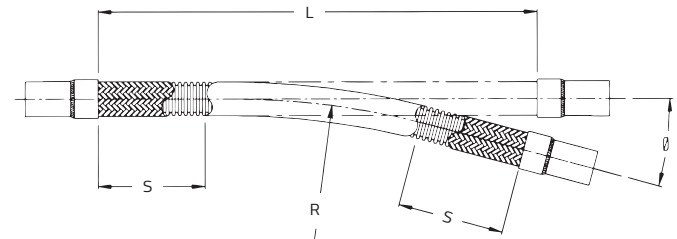

Formula:  $L = 2S + (\theta/57.3)R$

### Vertical Loop With Movement In Two Directions (combination loop)

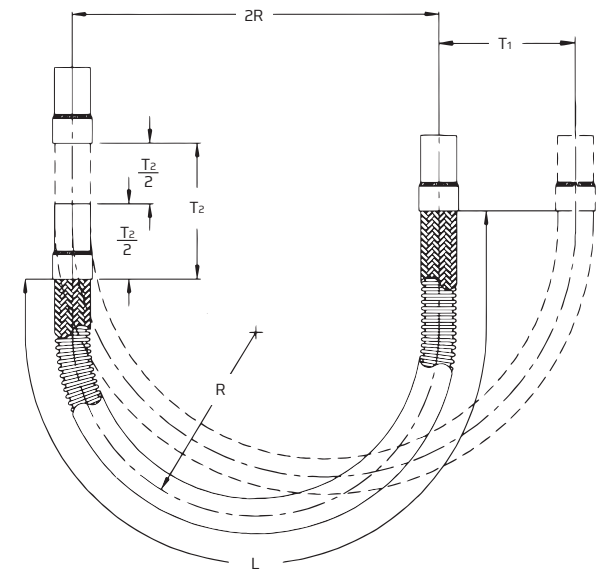

Formula:  $L = 4R + 1.57T_1 + (T_2/2)$

# Selecting & Installing Metal Hose Assemblies

## Media Flow Velocity

When gas or liquid being conveyed in a corrugated metal hose exceeds certain limits, resonant vibration can occur. Resonance may cause a very rapid failure of the assembly. In applications where product velocities exceed the limits shown in the chart below, a revision of the assembly design might include:

1. Addition of an interlocked metal hose liner
2. An increase in the corrugated hose I.D.
3. A combination of the above

## Velocity in Metal Hose

Installation Configuration	Maximum Product Velocity Feet/Second (Meter/Second)			
	Unbraided		Braided	
	Dry Gas	Liquid	Dry Gas	Liquid
Straight Run	100 (30)	50 (15)	150 (46)	75 (23)
45 Degree Bend	75 (23)	40 (12)	115 (35)	60 (18)
90 Degree Bend	50 (15)	25 (8)	75 (23)	40 (12)
180 Degree Bend	25 (8)	12 (4)	38 (12)	19 (6)

## Pressure Drop

Pressure drop in a piping system is often a concern for the designer. Compared to rigid pipe, there is always a greater pressure drop in corrugated metal hose. The following graphs are offered as aids in estimating pressure drop in corrugated hose conveying water and air. The values derived are approximate and apply only to straight-line installations. Bends and fittings can increase the pressure drop.

### Pressure Drop Graph For Water

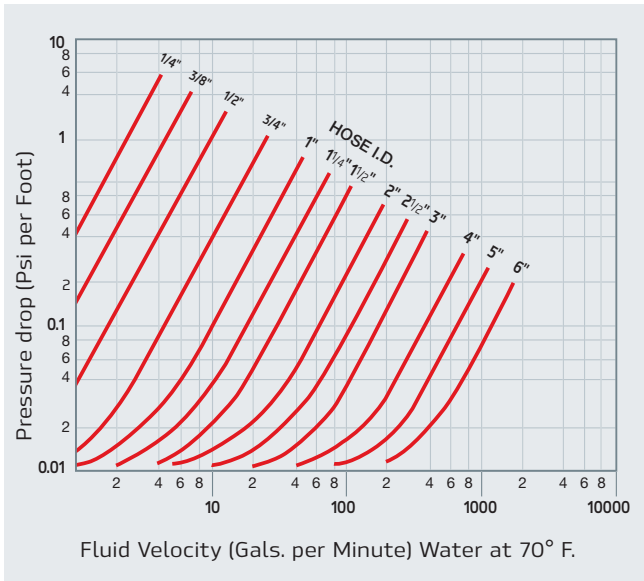

### Pressure Drop Graph For Air

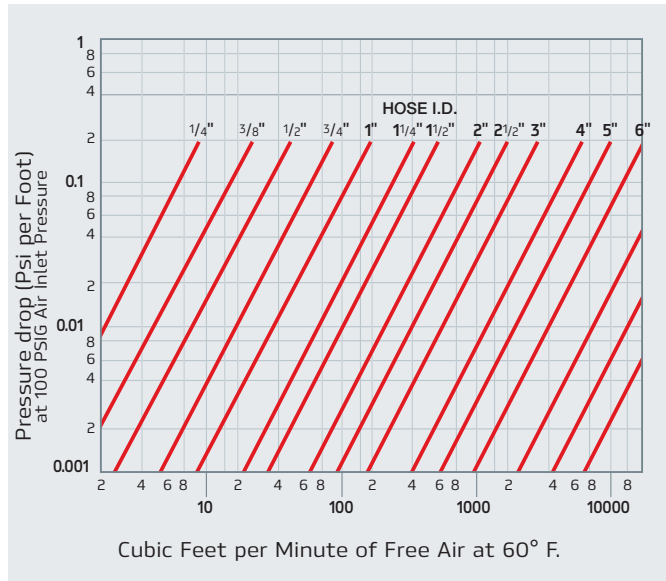

# Selecting & Installing Metal Hose Assemblies

## Vibration

The following graph is a representative guideline for estimation purposes only. For any questions, or if your application is near the “Consult Factory” region, please contact your HAM-LET local representative.

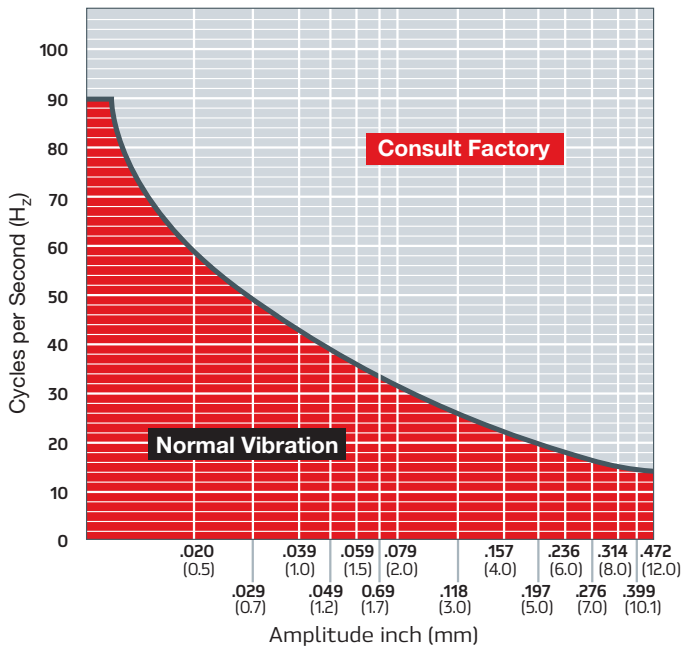

When installing a hose assembly in a vibration application, make sure to install it so the axis of the hose is perpendicular to the direction of the vibration.

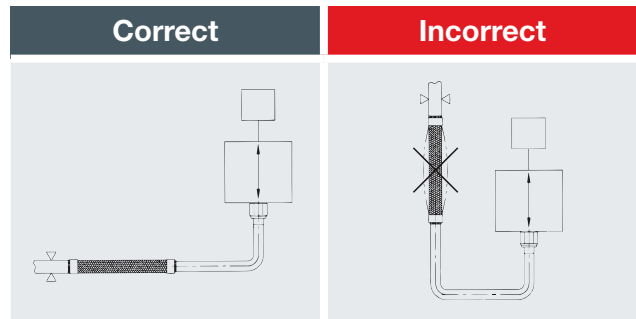



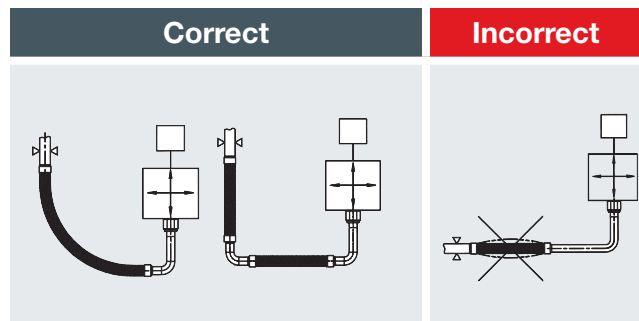



If there is vibration in more than one direction, either install a longer hose bent at 90° or install a “Dog Leg” assembly.

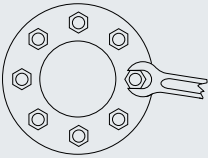
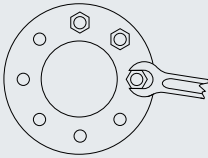
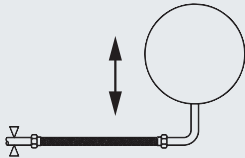
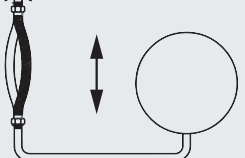
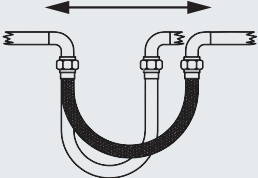

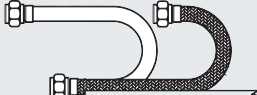
# Selecting & Installing Metal Hose Assemblies

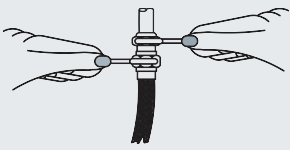
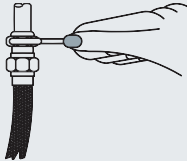
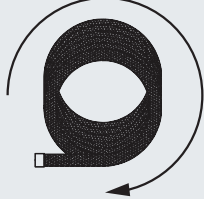
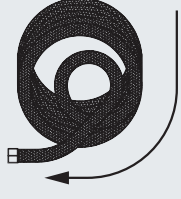
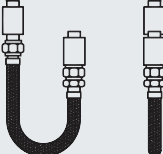
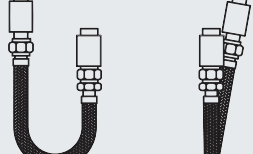
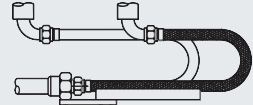
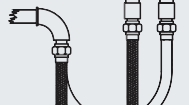
## Installation Do's & Don'ts

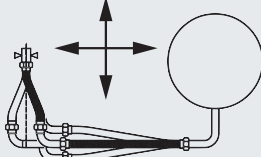
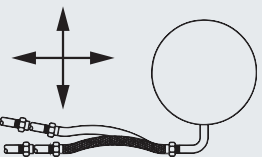
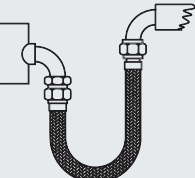
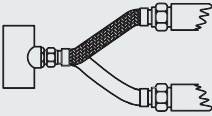
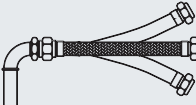
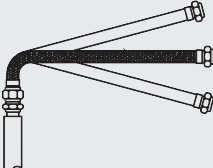
Do's	Don'ts	Do's	Don'ts
			
			
			
			
			
			

# Metal Hoses - Ordering Information

OPTIONAL

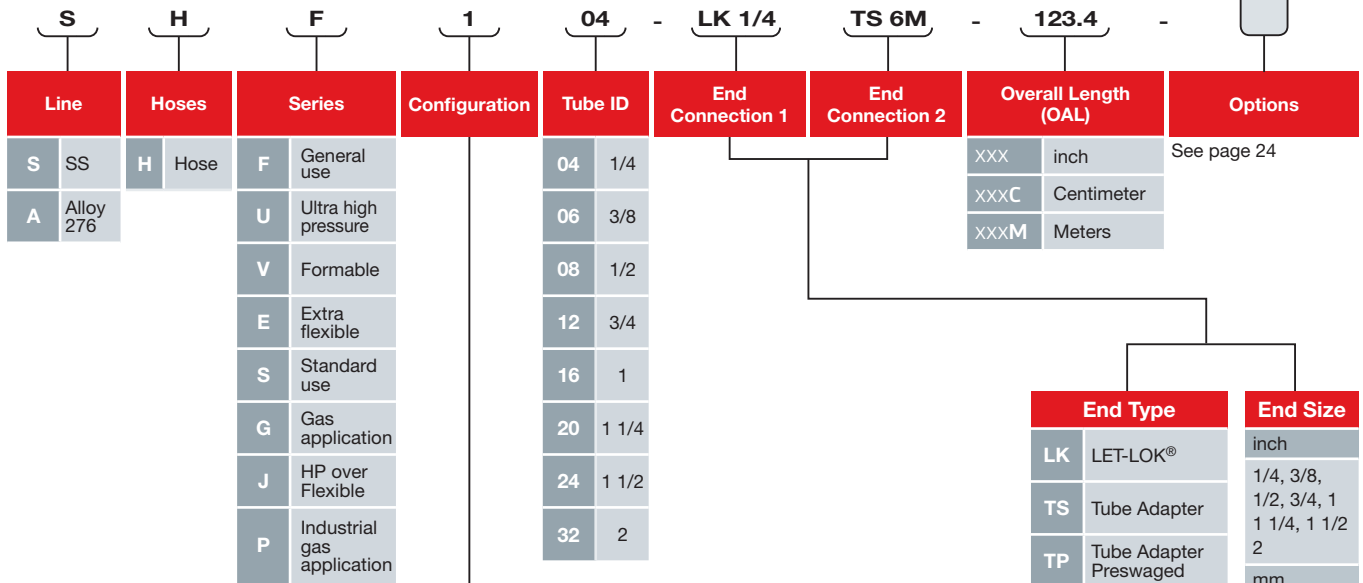

Line		Hoses		Series		Configuration	Tube ID		End Connection 1	End Connection 2	Overall Length (OAL)		Options
S	SS	H	Hose	F	General use	1	04	1/4	LK 1/4	TS 6M	XXX	inch	See page 24
A	Alloy 276			U	Ultra high pressure		06	3/8			XXXC	Centimeter	
				V	Formable		08	1/2			XXXM	Meters	

Series	Configuration	Tube Material	Braid Material	# of braids
F	0	316L	-	0
	1	316L	304	1
	2	316L	304	2
	3	321	-	0
	4	321	304	1
	5	321	304	2
	6	316L	316	1
	7	316L	316	2
	8	321	316	1
9	321	316	2	
U	0	321	-	0
	1	321	321	1
	2	321	321	2
	3	316L	-	0
	4	316L	321	1
5	316L	321	2	
V	0	321	-	0
	1	321	304	1
	2	316L	-	0
	3	316L	304	1
E	0	316L	-	0
	1	316L	304	1
	2	316L	304	2
	3	321	-	0
	4	321	304	1
	5	321	304	2
	6	316L	316	1
	7	316L	316	2
	8	321	316	1
9	321	316	2	

## Configuration

Series	Configura-tion	Tube Material	Braid Material	# of braids
F	0	316L	-	0
	1	316L	304	1
	2	316L	304	2
	3	321	-	0
	4	321	304	1
	5	321	304	2
	6	316L	316	1
	7	316L	316	2
	8	321	316	1
9	321	316	2	
U	0	321	-	0
	1	321	321	1
	2	321	321	2
	3	316L	-	0
	4	316L	321	1
5	316L	321	2	
V	0	321	-	0
	1	321	304	1
	2	316L	-	0
	3	316L	304	1
E	0	316L	-	0
	1	316L	304	1
	2	316L	304	2
	3	321	-	0
	4	321	304	1
	5	321	304	2
	6	316L	316	1
	7	316L	316	2
	8	321	316	1
9	321	316	2	

Series	Configura-tion	Tube Material	Braid Material	# of braids
S	0	316L	-	0
	1	316L	304	1
G	0	316L	304	1
	1	316L	304	2
J	0	316L	-	0
	1	316L	304	1
	2	316L	304	2
	3	321	-	0
	4	321	304	1
	5	321	304	2
	6	316L	316	1
	7	316L	316	2
	8	321	316	1
9	321	316	2	
P	0	316L	304	1
	1	316L	304	2

End Type	End Size	
LK	LET-LOK®	inch
TS	Tube Adapter	1/4, 3/8, 1/2, 3/4, 1 1/4, 1 1/2
TP	Tube Adapter Preswaged	2
GF	Face Seal Female Swivel	mm
GM	Face Seal Male Swivel	6M, 8M, 10M, 12M, 18M, 25M, 38M
FP	Female Pipe NPT	
MP	Male Pipe NPT	
FG	Female BSP-P	
MG	Male BSP-P	
BW	Butt Weld Adapter	
HL	ONE-LOK®	
UH	UH-Line (Vacuum only)	
FH	Female Flare 37°	
MF	Male Flare 37°	
TC	Sanitary flange Tri-clamp	
LW	Long Butt Weld	

## Warning!

The system designer and user have the sole responsibility for selecting products suitable for their special application requirements, ensuring their safe and trouble-free installation, operation, and maintenance. Application details, material compatibility and product ratings should all be considered for each selected product. Improper selection, installation or use of products can cause property damage or personal injury.

# Metal Hoses - Options

Test		Cleaning		Internal Lamina		Outer Cover		Special Type		Tagging			
H	Helium Leak Test 1x10 <sup>-9</sup> Std. CC/Sec	O	Oxygen Cleaning	L	Liner	R	Protective Cover	E	EN 10380 Certified	T	Paper Tag	None	On One End
						J	Insulating Jacket			M	Metal Tag <sup>(1)</sup>	B	Both Ends
Y	Hydraulic Test					A	Armor			P	Plastic Tag		
						J1	Thermal Insulation Cover						
						N	Interlock bend restrictor						
						X	Anti whip external safety cable						

(1) One end metal tag with MWP marking - is supply as standard (no need to mark this option to have this tag)

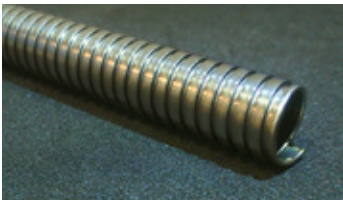

### Armor Protection

A mechanical armor can be installed with the hose assembly. This type of armor consists of a hard metallic shell protecting the flexible regions of the hose



### Protective Cover

For lighter protection of the corrugated hose and braid, plastic scuff guards can be installed with hose.



### Insulating Jacket

High temperature insulation of the hose exterior is available by adding an insulated protective jacket. The jacket consists of braided fiberglass insulation, covered and impregnated with silicone rubber that is then installed over the corrugated hose and sealed. The Insulation jacket can also be used to prevent ambient heat from being conveyed to the media or to reduce media heat loss.



### Thermal Insulation Cover

Thermal insulation of the hose exterior by adding thermal insulation cover. Reduces heat loss of media by decreasing conduction and convection heat exchanges with environment.



### Certifications

Materials, Standard Conformance and testing certificates are available. Other customer specific certificates are available upon request.



### Tagging

Customer or system information can be marked on hose assemblies using cardboard, plastic, and metal tags or permanently engraved onto braid collars. Tags and markings can be applied on single or both ends of assemblies.



# HAM-LET PTFE HOSES

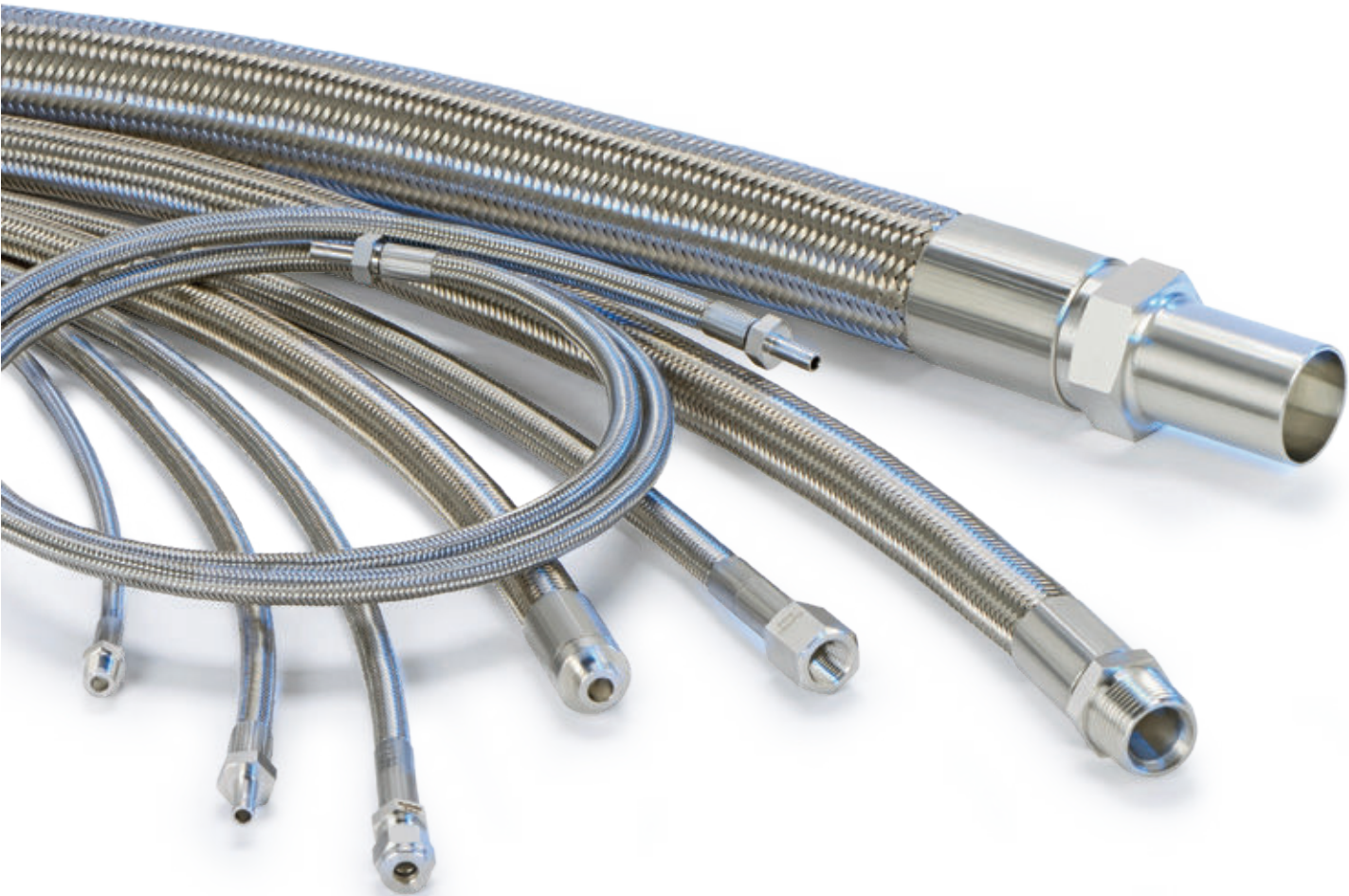

# HAM-LET PTFE Hoses

## General

PTFE stainless steel braided hose is an ideal solution for permanent or temporary connections for liquids. It makes fabrication easier, and it facilitates connect/disconnect and cleaning. Variable length, high flexibility, high pressures and broad chemical compatibility are among the features that make this hose the preferred solution for many applications.

HAM-LET PTFE hoses are available in smooth, convoluted or conductive carbon lined core with stainless-steel braid or silicon covered stainless-steel braided.

## Testing & Packing

All Hoses are Hydrostatically tested at 1.5xMAWP.

All Hoses packed individually in a plastic bag, end connections are capped.

## Features

- PTFE core with all stainless steel braid and connections
- Non-contaminating, Non-absorbent, will not impart taste or odor
- Non-aging & non-stick surface
- Easy to clean, drain easily
- True I.D., Low friction
- LET-LOK®, ONE-LOK®, Male & Female NPT, Mini Sanitary Flange.
- ID Sizes: 1/8" up to 2".
- Max. pressure 3250 psi (224 bar), safety factor 1 to 4.
- Working temperature: -100° ~ +450° F (-73° ~ + 232°C)
- Pack and Validated for high purity service with a corresponding fittings:
  1. Approved DIN EN 16643 standard
  2. Approved Food and Drug Administration (FDA) 21CFR177.1550

## Chemical Compatibility:

PTFE has one of the highest levels of chemical compatibility. Following is the list of materials that require some level of consideration:

The following materials **are not recommended** for use with PTFE hosing:

- Elemental Sodium
- Elemental Potassium
- Elemental Lithium

**The materials listed below are only questionable if conveyed in conjunction with high temperature and pressure and/or a combination thereof:**

- Fluorine (F<sub>2</sub>)
- Iodine Pentafluoride
- 80% and over Sodium Hydroxide
- Aluminum Chloride (at elevated temps)
- Ammonia (NH<sub>3</sub>)
- Temperature
- 70% Nitric Acid

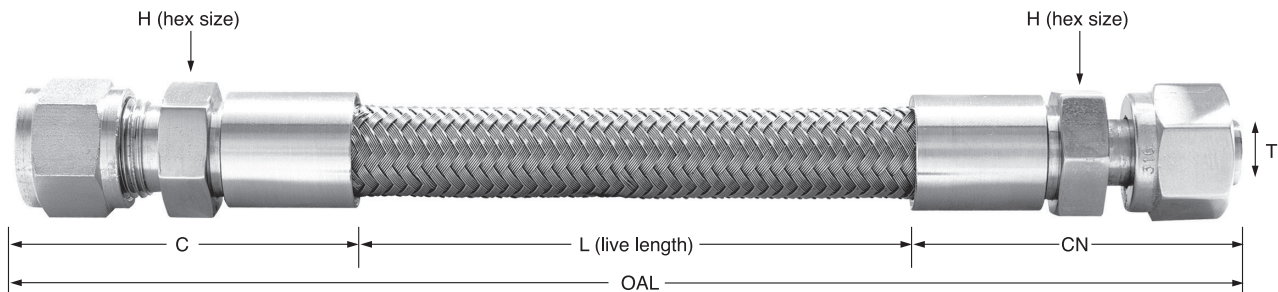

## General

General use smooth PTFE core hoses.

## Features

- Tube I.D. 1/8" up to 1"
- Pressure rating Vacuum to 3,500 psi (241 bar)
- Min Bend radius 1.5 inch (38.1mm)
- Conductive inner lining available

## THT Series - Smooth PTFE Core SS Braided Hose

Inside Diameter		Number of Braids	Maximum Working Pressure		Dynamic Minimum Bend Radius		Outside Diameter		Burst Pressure		Weight Per Foot	Weight Per Meter
(inch)	(mm)		(psi)	(bar)	(inch)	(mm)	(inch)	(mm)	(psi)	(bar)		
1/8	3.18	1	3,750	258	1.5	38	0.25	6.35	15,000	1,034	0.05	0.07
1/4	6.35	1	3,200	221	3.0	76	0.38	9.65	12,800	884	0.1	0.15
3/8	9.53	1	2,500	172	5.0	127	0.50	12.70	10,000	688	0.12	0.18
1/2	12.70	1	2,000	138	6.5	165	0.65	16.51	8,000	552	0.16	0.24
3/4	19.05	1	1,000	69	9.0	229	0.89	22.61	4,000	276	0.22	0.33
1	25.40	1	1,000	69	12.0	305	1.14	28.96	4,000	276	0.51	0.76



### Materials of Construction

Part	Material
Tube	PTFE
Braid	SS 304
End Connections	SS 316L

## General

Special design for pharmaceutical, Food & beverages and biotech applications. Silicon cover protect the braid from particles or other external contamination and distend high temperatures.

## Features

- Tube I.D. 1/8" up to 1"
- Pressure rating Vacuum to 3250psi (224bar)
- Min Bend radius 1.5inch (38.1mm)

## THS Series - Silicon Covered Smooth PTFE Core SS Braided Hose

Inside Diameter		Number of Braids	Maximum Working Pressure		Dynamic Minimum Bend Radius		Outside Diameter		Burst Pressure		Weight Per Foot	Weight Per Meter
(inch)	(mm)		(psi)	(bar)	(inch)	(mm)	(inch)	(mm)	(psi)	(bar)		
1/8	3.18	1	3,750	258	1.5	38	0.43	10.9	15,000	1,034	0.11	0.16
1/4	6.35	1	3,200	221	3.0	76	0.50	12.7	12,800	884	0.13	0.19
3/8	9.53	1	2,500	172	5.0	127	0.65	16.5	10,000	688	0.15	0.22
1/2	12.70	1	2,000	138	6.5	165	0.81	20.6	8,000	552	0.18	0.27
3/4	19.05	1	1,000	69	9.0	229	1.02	25.9	4,000	276	0.34	0.51
1	25.40	1	1,000	69	12.0	305	1.36	34.5	4,000	276	0.57	0.85



### Materials of Construction

Part	Material
Tube	PTFE
Braid	SS 304
External cover	Silicon
End Connections	SS 316L

## General

Convuluted PTFE core for extra flexibility with larger IDs. Completely drainable hose. Durable for high pressures and high temperatures with lower profile.

## Features

- Tube I.D. 1/2" up to 2"
- Pressure rating up to 1500psi (103bar)
- Min Bend radius 2.5inch (63.5mm)
- Conductive inner lining available

## THC Series - Convuluted PTFE Core SS Braided Hose

Inside Diameter		Number of Braids (#)	Maximum Working Pressure		Dynamic Minimum Bend Radius		Outside Diameter		Burst Pressure		Weight Per Foot (lbs)	Weight Per Meter (kg)
inch	mm		psi	bar	inch	mm	inch	mm	psi	bar		
1/4	6.35	1	2,500	172	0.71	18	0.48	12.3	10,000	688	-	-
3/8	9.53	1	2,000	136	0.79	20	0.60	14.75	8,000	544	-	-
1/2	12.70	1	1,500	103	0.98	25	0.74	18.80	6,000	414	0.19	0.28
3/4	19.05	1	1,100	76	2.52	64	0.97	24.64	4,400	303	0.27	0.40
1	25.40	1	750	52	3.50	89	1.29	32.77	3,000	207	0.39	0.58
1 1/2	38.10	1	700	48	5.98	152	1.90	48.26	2,800	193	0.75	1.12
2	50.80	1	525	36	7.87	200	2.42	61.47	2,100	145	0.89	1.32



### Materials of Construction

Part	Material
Tube	PTFE
Braid	SS 304
End Connections	SS 316L

## General

Nonmetal smooth PTFE core hoses with fiberglass braid

## Features

- Tube I.D. 1/4" up to 3/4"
- Pressure rating up to 800psi (55bar)
- Min Bend radius 2.75inch (70mm)

## THB Series - Smooth PTFE Core Fiberglass Braided Hose

Inside Diameter		Number of Braids (#)	Maximum Working Pressure		Dynamic Minimum Bend Radius		Outside Diameter		Burst Pressure		Weight Per Foot (lbs)	Weight Per Meter (kg)
inch	mm		psi	bar	inch	mm	inch	mm	psi	bar		
1/4	6.35	1	800	55	2.75	70	0.43	11	3,200	220	0.06	0.09
3/8	9.53	1	800	55	3.25	83	0.58	15	3,200	220	0.12	0.18
1/2	12.7	1	800	55	5.25	133	0.73	19	3,200	220	0.13	0.19
3/4	19.05	1	400	27	6.50	165	0.98	25	1,600	110	0.20	0.30



### Materials of Construction

Part	Material
Tube	PTFE
Braid	Fiberglass single braid
End Connections	SS 316L

## General

Convolute Insulated PTFE core with light weight UV resistant Aramid yarn braid. Compatible with all racing fluids and fuels.

## Features

- Tube I.D. 3/8" up to 3/4"
- Pressure rating Vacuum to 1250psi (86bar)
- Min Bend radius 2.5inch (63.5mm)
- Conductive inner lining available

## THN Series - Convolute Insulated PTFE Core Aramid Braided Hose

Inside Diameter		Number of Braids	Maximum Working Pressure		Dynamic Minimum Bend Radius		Outside Diameter		Burst Pressure*	
inch	mm		psi	bar	inch	mm	inch	mm	psi	bar
3/8	9.53	1	1,250	86	2.50	63.5	0.73	18.54	3,750	258
1/2	12.7	1	1,000	69	3.50	88.9	0.86	21.84	3,000	207
5/8	15.89	1	750	52	4.00	101.6	0.96	24.77	2,250	156
3/4	19.05	1	500	35	4.50	114.3	1.12	28.45	1,500	105

\*Pressure rating: 3 to 1 safety factory



### Materials of Construction

Part	Material
Tube	PTFE
Insulating layer	Insulating wrap
Braid	Aramid yarn
End Connections	SS 316L

## General

Nominal size PTFE core. Special design for pharmaceutical, food and beverage as well as biotech applications. The red silicone cover protects the braid from particles, other external contamination and extended high temperatures.

## Features

- Tube I.D. 1/4" up to 1/2"
- Pressure rating Vacuum to 3000psi (207bar)
- Min Bend radius 1.5inch (38.1mm)

## THP Series - Red Silicon Covered Smooth PTFE Core SS Braided Hose

Inside Diameter		Number of Braids	Maximum Working Pressure		Dynamic Minimum Bend Radius		Outside Diameter		Burst Pressure		Weight Per Foot	Weight Per Meter
inch	mm		psi	bar	inch	mm	inch	mm	psi	bar		
1/4	6.35	1	3,000	207	2.00	51	0.41	10.5	12,000	827	0.09	0.13
3/8	9.53	1	2,500	172	4.00	102	0.55	14	10,000	689	0.12	0.18
1/2	12.7	1	2,000	138	5.20	132	0.65	16.6	8,000	552	0.14	0.2



### Materials of Construction

Part	Material
Tube	PTFE
Braid	SS 304
End Connections	SS 316L



## General

Smooth PTFE core hose with additional fiberglass middle layer and external stainless steel braid for increased flexibility and insulation

## Features

- Tube I.D. 1/4" up to 1"
- Pressure rating Vacuum to 3,500 psi (241 bar)
- Min Bend radius 1.25 inch (32 mm)
- Conductive inner lining available

## THR Series - Smooth PTFE Core Fiberglass middle layer SS Braided Hose

Inside Diameter		Number of Braids	Maximum Working Pressure		Dynamic Minimum Bend Radius		Outside Diameter		Burst Pressure		Weight Per Foot	Weight Per Meter
inch	mm		psi	bar	inch	mm	inch	mm	psi	bar		
1/4	6.35	1	3,500	241	-	-	0.44	11.18	14,000	965	0.13	0.19
3/8	9.53	1	3,000	207	4.0	102	0.57	14.53	12,000	827	0.18	0.27
1/2	12.70	1	1,800	124	5.5	140	0.75	19.15	7,200	496	0.24	0.36
3/4	19.05	1	1,000	69	-	-	1.00	25.40	4,000	276	0.37	0.55
1	25.40	1	1,000	69	11.5	292	1.41	34.69	4,000	276	0.49	0.72



## Materials of Construction

Part	Material
Tube	PTFE
Inner Braid	Fiberglass
Outer Braid	SS 304
End Connections	SS 316L



# PTFE Hoses - Ordering Information

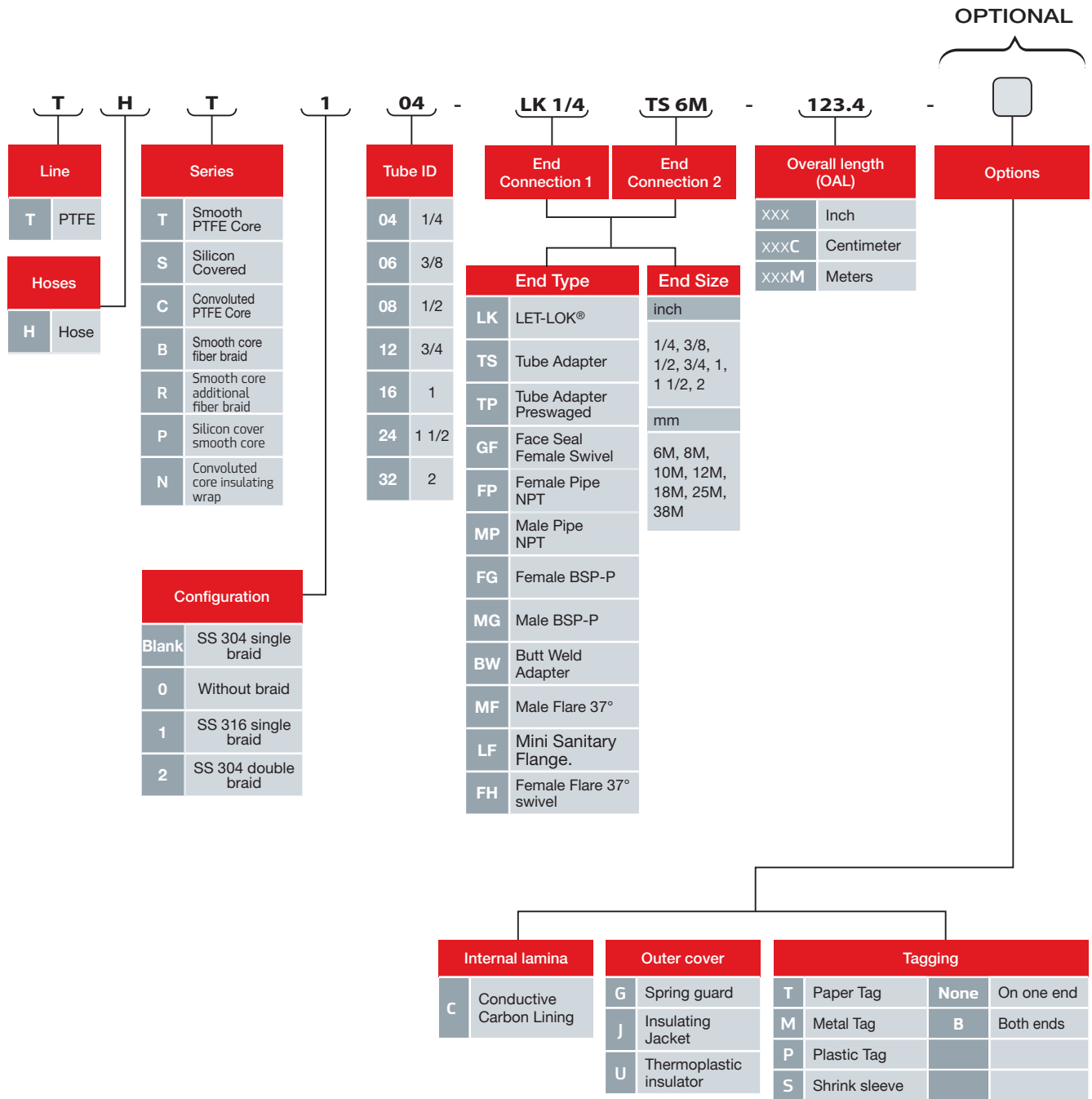

## Warning!

The system designer and user have the sole responsibility for selecting products suitable for their special application requirements, ensuring their safe and trouble-free installation, operation, and maintenance. Application details, material compatibility and product ratings should all be considered for each selected product. Improper selection, installation or use of products can cause property damage or personal injury.



# HAM-LET RUBBER HOSES



# HAM-LET Rubber Hoses

## General

HAM-LET RHG rubber hoses are designed for pneumatic and hydraulic applications, automotive industry, shop air systems and general industrial maintenance.

No silicone is used during hose production.

RHG Hoses are to be used with HAM-LET HOSE END™ connectors.

\* For HAM-LET HOSE END™ variety, see HAM-LET catalog, page 67.

## Testing & Packing

All Hose assemblies are Hydrostatically tested to 1.5xMWP.

All Hose assemblies are packed individually in a plastic bag, end connections are capped.

## Features

- RUBBER core with all stainless steel or brass end connections assemblies per EN 16643:2016
- Available in 6 colors: Black, Blue, Red, Green, Grey and Yellow
- Easy to clean, drains easily
- True I.D.
- LET-LOK®, ONE-LOK®, NPT, BSPT, BSPP and SAE 37° Flare end connections.
- ID Sizes: ¼” up to 1”
- Minimum bend radius 2.56 inch (65mm)
- Max. pressure 300 psi (20.7 bar), safety factor 1 to 4
- Working temperature: -40° ~ +190° F (-40° ~ + 88°C)
- Inner tube oil & heat resistant synthetic rubber (RMA Class A high oil resistance)
- Cover weather, abrasion & oil resistant Nitrile synthetic rubber
- (RMA Class B medium-high oil resistance)
- External layer has excellent abrasion, weather condition and oil resistance. Flame resistance meets MSHA 2G-14C/14 standards.
- Nonconductive (R > 1MΩ/inch at 1000 V DC)

## RHG Series - Smooth Rubber Core Synthetic Braided Hose

Inside Diameter		Maximum Working Pressure		Minimum Bend Radius		Outside Diameter		Burst Pressure		Weight Per Foot	Weight Per Meter
inch	mm	psi	bar	inch	mm	inch	mm	psi	bar	lbs	kg
1/4	6.35	300	20.7	2.56	65	0.54	13.7	1,200	82.7	0.09	0.13
3/8	9.53	300	20.7	2.95	75	0.69	17.5	1,200	82.7	0.14	0.21
1/2	12.7	300	20.7	5.12	130	0.81	20.6	1,200	82.7	0.17	0.25
5/8	15.88	300	20.7	5.91	150	0.93	23.6	1,200	82.7	0.2	0.30
3/4	19.05	300	20.7	7.09	180	1.07	27.2	1,200	82.7	0.26	0.39
1	25.4	300	20.7	8.0	203	1.34	34.0	1,200	82.7	0.34	0.51



## Materials of Construction

Part	Material
Tube	Rubber
Braid	Single fiber braid
External Cover	Nitrile synthetic rubber
End Connections	SS 316L

Color Code	Hose Cover Color
Blank	Black
V1	Red
V2	Blue
V3	Green
V4	Yellow
V5	Grey

# RUBBER HOSES - Ordering Information

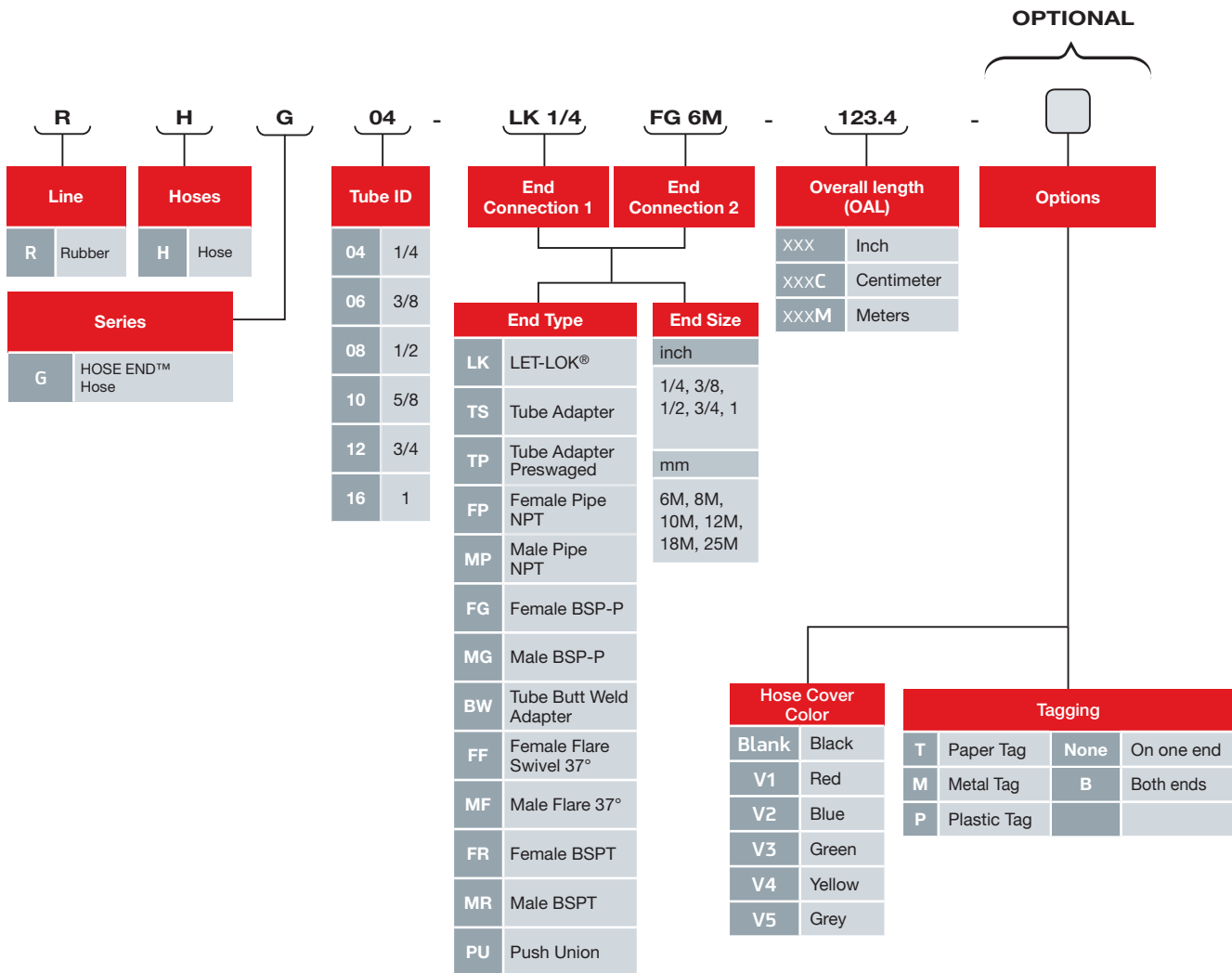

\*Note

\* For POP geometry add "P" before End type/  
**Example:** RHG04-PLK1/4-123.4

## Warning!

The system designer and user have the sole responsibility for selecting products suitable for their special application requirements, ensuring their safe and trouble-free installation, operation, and maintenance. Application details, material compatibility and product ratings should all be considered for each selected product. Improper selection, installation or use of products can cause property damage or personal injury.





# HAM-LET NYLON HOSES



# HAM-LET N YLON Hoses

## General

Ham-Let nylon hoses designed for wide range of applications including Automotive, Fuel and Oil transfer, Hydraulic lines, Instrumentation, Compressed air and much more.

Variable length, Lightweight, Excellent flexibility, Durability for increased number of cycles, chemical and corrosion resistance and very high working pressure making Ham-Let nylon hoses great solution for your need.

## Testing & Packing

All hoses are Hydrostatically tested to 1.5 MWP.  
All hoses packed individually in plastic bag, end connections are capped.

## Features

- ID sizes 1/4" to 1"
- Max. pressure 5000psi (xx bar), safety factor 1 to 4

## General

Special design for high pressure conduction of CNG gas

## Features

- Tube I.D. 1/4" up to 1"
- Pressure rating 13.5psi Vacuum to 5000psi (345 bar)
- Min Bend radius 1.8inch (45mm)
- On request twin-line or multi-line construction available
- Electrical resistance lower than 0.12 MOhm/m according to ISO 8031
- Working temperature -40° to 180° F (-40° to +82°C)
- External cover is micro perforated anti abrasion RED Polyurethane
- Meet or exceed ISO 15500-17 and SAE 100R8 standards

# NHG Series - Nylon reinforced Hose for CNG gas

Inside Diameter		Number of Braids	Maximum Working Pressure		Dynamic Minimum Bend Radius		Outside Diameter		Burst Pressure		Weight Per Foot	Weight Per Meter
inch	mm		(psi)	bar	inch	mm	inch	mm	psi	bar		
1/4	6.35	2	5,000	345	1.8	45	0.49	12.5	20,000	1,379	0.07	0.11
3/8	9.53	2	5,000	345	3.0	75	0.65	16.5	20,000	1,379	0.10	0.15
1/2	12.7	2	5,000	345	3.7	95	0.87	22	20,000	1,379	0.17	0.25
3/4	19.05	2	5,000	345	7.3	185	1.14	29	20,000	1,379	0.24	0.36
1	24.4	2	5,000	345	9.1	230	1.52	38.5	20,000	1,379	0.34	0.51



## Materials of Construction

Part	Material
Tube	Electrically conductive Polyamide
Braid	2 textile fibers
External cover	Polyurethane
End Connections	SS 316L

## General

Lightweight flexible hose designed for isocyanate, polyols, solvents and paints.  
Pinpricked version supplied as standard.

## Features

- Tube I.D. 1/4" up to 1"
- Pressure rating 13.5psi Vacuum to 5000psi (345 bar)
- Min Bend radius 1.8inch (45mm)
- On request twin-line or multi-line construction available
- Electrical resistance lower than 0.12 MOhm/m according to ISO 8031
- Working temperature -40° to 180° F (-40° to +82°C)
- External cover is micro perforated anti abrasion Black ( Blue for Conductive option) Polyurethane
- Meet or exceed ISO 15500-17 and SAE 100R8 standards

## NHT Series - Nylon reinforced SAE 100R7

Inside Diameter		Number of Braids	Maximum Working Pressure		Dynamic Minimum Bend Radius		Outside Diameter		Burst Pressure		Weight Per Foot	Weight Per Meter
inch	mm		psi	bar	inch	mm	inch	mm	psi	bar		
1/4	6.4	2	2,900	200	1.4	35	0.46	11.8	11,603	800	0.06	0.09
3/8	9.7	2	2,538	175	2.2	55	0.63	16	10,152	700	0.10	0.15
1/2	13	2	2,030	140	3.0	75	0.80	20.3	8,122	560	0.15	0.22
3/4	19.2	2	1,305	90	5.7	145	1.04	26.5	5,221	360	0.20	0.3
1	25.6	2	1,015	70	7.9	200	1.28	32.5	4,061	280	0.25	0.37

## NHT Conductive option

Inside Diameter		Number of Braids	Maximum Working Pressure		Dynamic Minimum Bend Radius		Outside Diameter		Burst Pressure		Weight Per Foot	Weight Per Meter
inch	mm		psi	bar	inch	mm	inch	mm	psi	bar		
1/4	6.4	2	3,306	228	1.6	40	0.50	12.7	13,227	912	0.07	0.1
3/8	9.7	2	3,306	228	2.4	60	0.68	17.3	13,227	912	0.12	0.18
1/2	13	2	2,030	140	3.0	75	0.80	20.3	8,122	560	0.14	0.21
3/4	19.2	2	1,305	90	5.7	145	1.04	26.5	5,221	360	0.2	0.3
1	25.6	2	1,015	70	7.9	200	1.28	32.5	4,061	280	0.25	0.37

addition of conductive fibre to braid - anti static hose ( $R < 3 \times 10^4 \text{ O/M}$ )



## Materials of Construction

Part	Material
Tube	Polyamide
Braid	Double Polyester layers
External cover	Polyurethane
End Connections	SS 316L

## General

Lightweight flexible hose designed for isocyanate, polyols, solvents and paints.  
Pinpricked version supplied as standard.

## Features

- Tube I.D. 1/4" up to 1"
- Pressure rating 13.5psi Vacuum to 5000psi (345 bar)
- Min Bend radius 1.8inch (45mm)
- On request twin-line or multi-line construction available
- Electrical resistance lower than 0.12 MOhm/m according to ISO 8031
- Working temperature -40° to 180° F (-40° to +82°C)
- External cover is micro perforated anti abrasion Black ( Blue for Conductive option) Polyurethane
- Exceed ISO 3949, EN 855 and SAE 100R8 standards

## NHP Series - Nylon reinforced SAE 100R8

Inside Diameter		Number of Braids	Maximum Working Pressure		Dynamic Minimum Bend Radius		Outside Diameter		Burst Pressure		Weight Per Foot	Weight Per Meter
inch	mm		psi	bar	inch	mm	inch	mm	psi	bar		
1/4	6.4	2	5,076	350	2.0	50	0.46	11.8	20,305	1,400	0.06	0.08
3/8	9.7	2	4,061	280	2.8	70	0.63	16	16,244	1,120	0.09	0.14
1/2	13	2	3,553	245	3.7	95	0.80	20.3	14,213	980	0.15	0.22
3/4	19.2	2	2,393	165	5.9	150	1.04	26.5	9,572	660	0.23	0.34
1	25.6	2	2,103	145	7.9	200	1.37	34.7	8,412	580	0.32	0.48

## NHP Conductive option

Inside Diameter		Number of Braids	Maximum Working Pressure		Dynamic Minimum Bend Radius		Outside Diameter		Burst Pressure		Weight Per Foot	Weight Per Meter
inch	mm		psi	bar	inch	mm	inch	mm	psi	bar		
1/4	6.4	2	5,076	350	2.0	50	0.46	11.8	20,305	1,400	0.07	0.1
3/8	9.7	2	4,061	280	2.8	70	0.66	16.7	16,244	1,120	0.11	0.17
1/2	13	2	3,553	245	3.7	95	0.80	20.3	14,213	980	0.15	0.22

addition of conductive fibre to braid - anti static hose ( $R < 3 \times 10^4$  O/M)

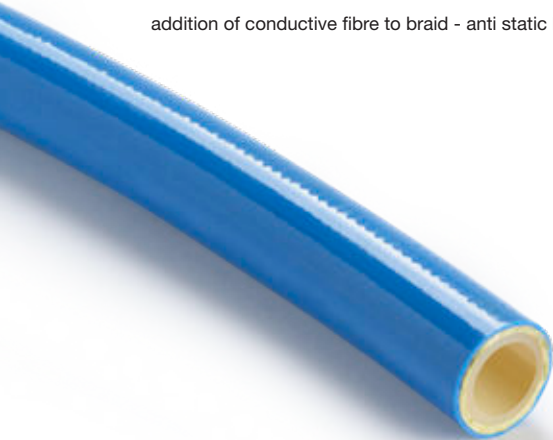

## Materials of Construction

Part	Material
Tube	Electrically conductive polyamide
Braid	Double Polyester layers
External cover	Polyurethane
End Connections	SS 316L

# NYLON HOSES - Ordering Information

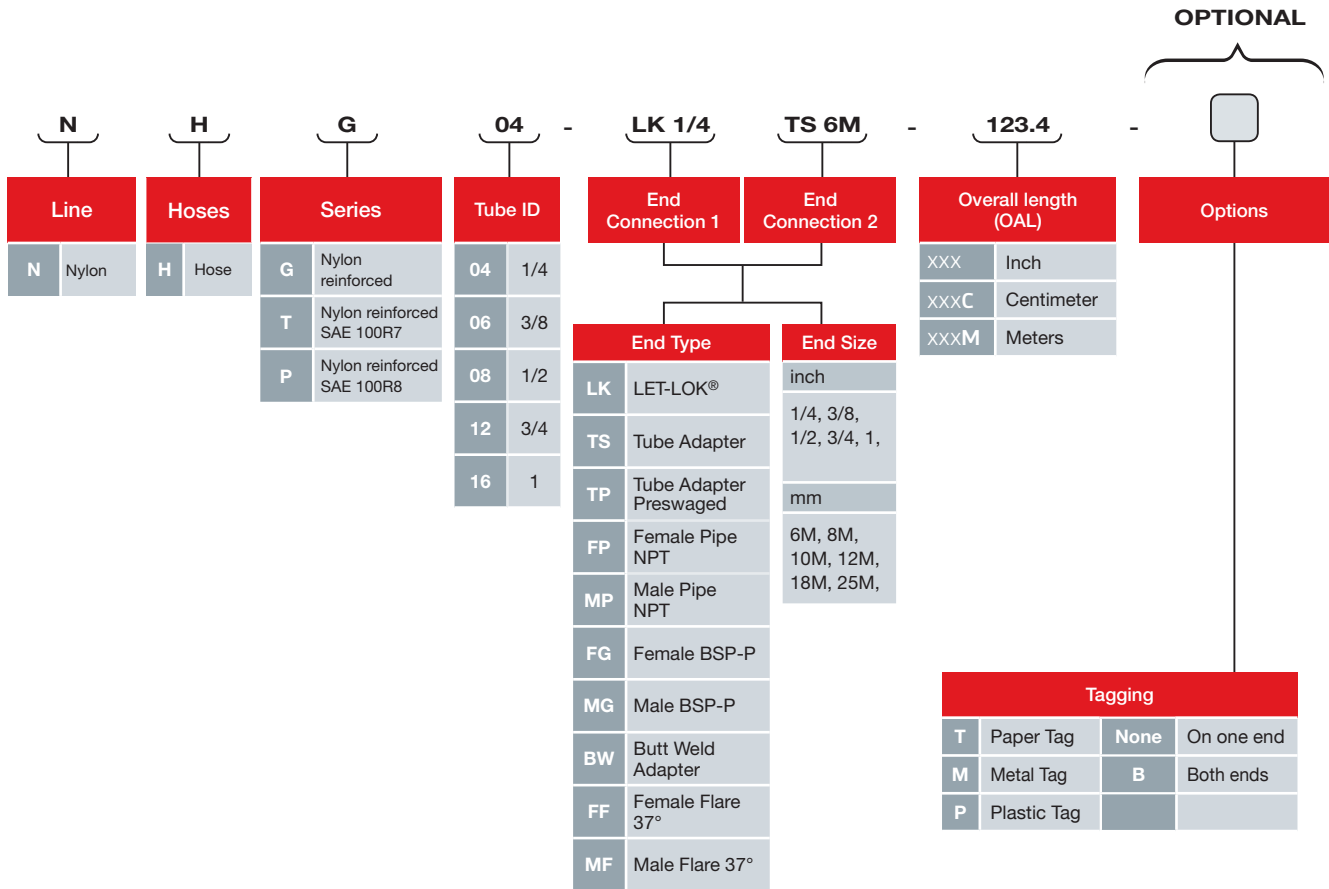

## Warning!

The system designer and user have the sole responsibility for selecting products suitable for their special application requirements, ensuring their safe and trouble-free installation, operation, and maintenance. Application details, material compatibility and product ratings should all be considered for each selected product. Improper selection, installation or use of products can cause property damage or personal injury.





# **HAM-LET** METAL HOSES COMPONENTS



# Bulk Metal Hoses

Available for ordering as:

- Reel of fix length 500 feet (152.4 meter) for sizes up to 1" (maximum 6 pieces in a reel, 10' minimum)
- Reel of fix length 425/325/200 feet (129.5/99.1/61 meter) for sizes 1-1/4"/1-1/2"/2" respectively (maximum 6 pieces in reel, 10' minimum)

## HOW TO ORDER

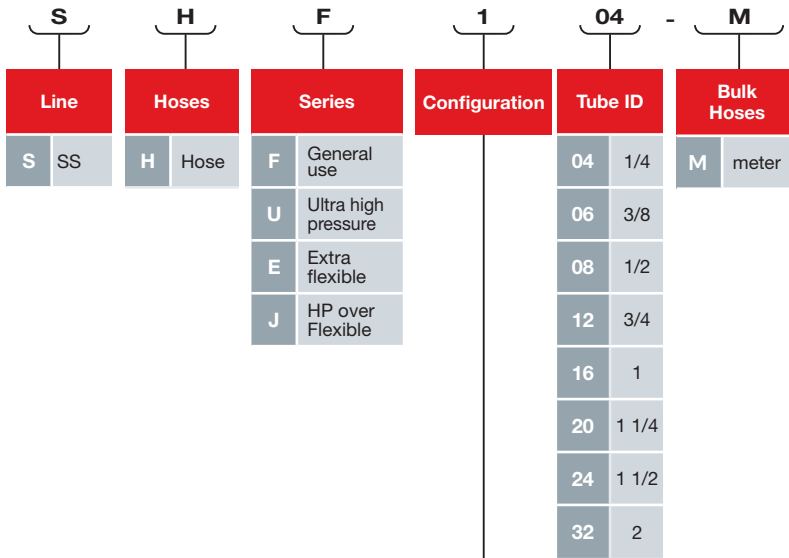

### Configuration

Series	Configuration	Tube Material	Braid Material	# of braids
F	0	316L	-	0
	1	316L	304	1
	2	316L	304	2
	3	321	-	0
	4	321	304	1
	5	321	304	2
	6	316L	316	1
	7	316L	316	2
	8	321	316	1
U	0	321	-	0
	1	321	321	1
	2	321	321	2
	3	316L	-	0
	4	316L	321	1
E	0	316L	-	0
	1	316L	304	1
	2	316L	304	2
	3	321	-	0
	4	321	304	1
	5	321	304	2
	6	316L	316	1
	7	316L	316	2
	8	321	316	1
9	321	316	2	

Series	Configuration	Tube Material	Braid Material	# of braids
J	0	316L	-	0
	1	316L	304	1
	2	316L	304	2
	3	321	-	0
	4	321	304	1
	5	321	304	2
	6	316L	316	1
	7	316L	316	2
	8	321	316	1
9	321	316	2	

For a complete range of end connections see the following pages, or the Ham-Let catalogue.

### Warning!

The system designer and user have the sole responsibility for selecting products suitable for their special application requirements, ensuring their safe and trouble-free installation, operation, and maintenance. Application details, material compatibility and product ratings should all be considered for each selected product. Improper selection, installation or use of products can cause property damage or personal injury.



# HAM-LET METAL HOSES COMPONENTS | FITTINGS

## LET-LOK TUBE FITTINGS

768LW

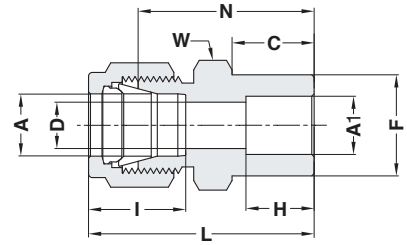
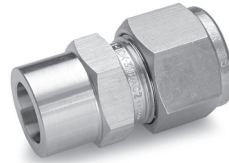

Ordering information (INCH)	A Tube O.D.		A1 Hose O.D.		C		D		W Hex. Flat	F		H		I		L		N	
	inch	mm	inch	mm	inch	mm	inch	mm	inch	inch	mm	inch	mm	inch	mm	inch	mm	inch	mm
768LW _ 1/8 X 1/8	1/8	3.17	1/8	3.17	0.34	8.64	0.09	2.28	7/16	0.31	7.87	0.25	6.35	0.5	12.7	1.14	28.96	0.88	22.35
768LW _ 1/4 X 1/4	1/4	6.35	1/4	6.35	0.41	10.4	0.19	4.8	1/2	0.44	11.2	0.31	7.9	0.6	15.2	1.32	33.53	1.03	26.16
768LW _ 1/4 X 3/8	1/4	6.35	3/8	9.52	0.47	11.9	0.19	4.8	5/8	0.62	15.8	0.38	9.65	0.6	15.2	1.41	35.96	1.13	28.6
768LW _ 3/8 X 1/4	3/8	9.52	1/4	6.35	0.41	10.4	0.19	4.8	5/8	0.44	11.2	0.31	7.9	0.66	16.8	1.42	36.06	1.13	28.7
768LW _ 3/8 X 3/8	3/8	9.52	3/8	9.52	0.47	11.9	0.28	7.1	5/8	0.62	15.8	0.38	9.65	0.66	16.8	1.48	37.6	1.19	30.23
768LW _ 1/2 X 1/4	1/2	12.7	1/4	6.35	0.41	10.4	-	-	-	0.44	11.2	0.31	7.9	-	-	-	-	-	-
768LW _ 1/2 X 1/2	1/2	12.7	1/2	12.7	0.47	11.9	0.41	10.4	13/16	0.75	19.05	0.5	12.7	0.9	22.9	1.62	41.15	1.22	31
768LW _ 3/4 X 3/4	3/4	19.05	3/4	19.05	0.47	11.9	0.62	15.8	1 1/16	1.05	26.7	0.56	14.2	0.96	24.4	1.71	43.43	1.31	33.28
768LW _ 1 X 1	1	25.4	1	25.4	0.56	14.2	0.88	22.35	1 3/8	1.36	34.5	0.75	19.2	1.23	31.2	2.07	52.58	1.59	40.4
768LW _ 1-1/4 X 1-1/4	1-1/4	32	1-1/4	32	0.66	16.9	1.09	27.7	1 3/4	1.73	44	0.75	19.2	1.62	41.2	2.76	70.1	1.89	48
768LW _ 1-1/2 X 1-1/2	1-1/2	38.35	1-1/2	38.35	0.71	18.1	1.34	34	2 1/8	1.97	50	0.9	22.9	19.7	50	3.18	80.78	2.11	53.6
768LW _ 2 X 2	2	51.15	2	51.15	1	25.4	1.81	46	2 3/4	2.48	63	1.19	30.4	2.66	67.6	4.16	105.84	2.69	68.5

Ordering information (METRIC)	A Tube O.D.	A1 Hose O.D.	C	D	W Hex. Flat	F	H	I	L	N
	mm	inch	mm	mm	mm	mm	mm	mm	mm	mm
768LW _ 6MM X 1/4	6	1/4	10.4	4.8	14	11.2	7.9	15.3	32.8	25.4
768LW _ 8MM X 1/4	8	1/4	10.4	4.8	15	11.2	7.9	16.2	35	27.5
768LW _ 10MM X 3/8	10	3/8	11.9	7.1	18	15.8	9.65	17.2	38.6	31
768LW _ 12MM X 1/2	12	1/2	11.9	9.5	22	19.05	12.7	22.8	41.1	31
768LW _ 18MM X 3/4	18	3/4	11.9	15.1	27	26.7	14.2	24.4	43.5	33.4
768LW _ 20MM X 3/4	20	3/4	11.9	-	-	26.7	14.2	26	-	-
768LW _ 25MM X 1	25	1	14.2	21.8	35	34.5	19.2	31.3	52.7	40.4
768LW _ 32MM X 1-1/2	32	1-1/2	18.1	-	-	50	22.9	-	-	-
768LW _ 38MM X 1-1/2	38	1-1/2	18.1	33.7	55	50	22.9	49.4	83.6	56

### ONE-LOK® ORDERING INFORMATION

ONE-LOK® fitting part numbers are constructed from symbols that identify the type of material and size of the fitting.

The ONE-LOK® part numbering system is the same as our LET-LOK® Tube Fittings, with the exception that you add an "H" between the prefix number and the "L" to designate the one ferrule design.

**768HLW**

Fitting type  
(male connector)

**SS**

SS = Stainless Steel

**1/4**

**x**

**1/4**

Tube O.D.                      1/4 O.D. Hose  
The O.D. size is always the first to described

# HAM-LET METAL HOSES COMPONENTS | FITTINGS

## TUBE ADAPTER

739 LW

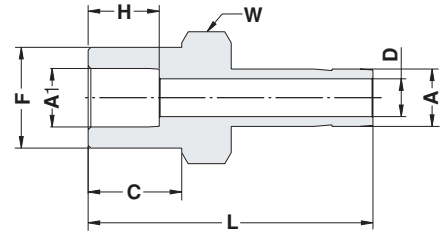
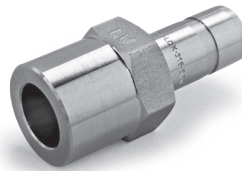

Ordering information (INCH)	A Tube O.D		A1		C		D		W Hex. Flat		F		H		L	
	inch	mm	inch	mm	inch	mm	inch	mm	inch	mm	inch	mm	inch	mm	inch	mm
739LW _ 1/4 X 1/4	1/4	6.35	1/4	6.35	0.41	10.4	0.17	4.2	1/2	0.44	11.2	0.31	7.9	1.25	31.7	
739LW _ 1/4 X 3/8	1/4	6.35	3/8	9.52	0.47	11.9	0.17	4.2	5/8	0.62	15.8	0.38	9.7	1.35	34.3	
739LW _ 3/8 X 3/8	3/8	9.52	3/8	9.52	0.47	11.9	0.28	7.11	5/8	0.62	15.8	0.38	9.7	1.42	36.7	
739LW _ 3/8 X 1/2	3/8	9.52	1/2	12.7	0.47	11.9	0.28	7.11	13/16	0.75	19.05	0.5	12.7	1.45	36.9	
739LW _ 1/2 X 1/2	1/2	12.7	1/2	12.7	0.47	11.9	0.39	9.91	13/16	0.75	19.05	0.5	12.7	1.67	42.42	
739LW _ 3/4 X 3/4	3/4	19.05	3/4	19.05	0.47	11.9	0.59	15	1-1/16	1.05	26.7	0.56	14.2	1.73	43.94	
739LW _ 1 X 3/4	1	25.4	3/4	19.05	0.74	11.9	0.8	20.3	1-1/16	1.05	26.7	0.56	14.2	2.12	54	
739LW _ 3/4 X 1	3/4	19.05	1	25.4	0.74	11.9	0.59	15	1-3/8	1.36	34.5	0.76	19.2	2	50.8	
739LW _ 1 X 1	1	25.4	1	25.4	0.74	11.9	0.8	20.3	1-3/8	1.36	34.5	0.76	19.2	2.33	59.2	
739LW _ 1-1/4 X 1-1/4	1-1/4	31.75	1-1/4	31.75	0.66	16.9	1.02	26	1-3/4	1.73	44	0.76	19.2	2.94	74.7	
739LW _ 1-1/2 X 1-1/2	1-1/2	38.1	1-1/2	38.1	0.71	18.1	1.24	31.6	2-1/8	1.97	50	0.9	22.9	3.54	90	

Ordering information (METRIC)	A Tube O.D		A1	C	D	W Hex. Flat		F	H	L
	mm	inch	mm	mm	mm	inch	mm	mm	mm	mm
739LW _ 6MMX 1/4	6	1/4	10.4	4	1/2	-	11.2	7.9	31.7	
739LW _ 8MM X 1/4	8	1/4	10.4	5.6	-	14	11.2	7.9	35.3	
739LW _ 10MMX 1/4	10	1/4	10.4	4.8	9/16	-	11.2	7.9	34	
739LW _ 10MMX 3/8	10	3/8	11.9	7.1	5/8	-	15.8	9.7	36	
739LW _ 12MM X 1/2	12	1/2	11.9	8.8	13/16	-	19.05	12.7	42.5	
739LW _ 18MM X 3/4	18	3/4	11.9	13.9	-	27	26.7	14.2	46.2	
739LW _ 25MM X 1	25	1	11.9	19.8	-	35	34.5	19.2	58.7	
739LW _ 38MM X 1-1/2	38	1-1/2	18.1	31.6	-	55	50	22.9	90	

## HAM-LET METAL HOSES COMPONENTS | FITTINGS

### MALE NPT IP98TS MP

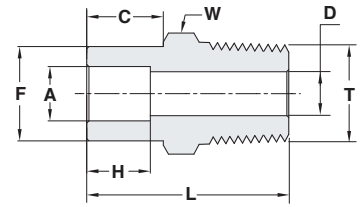

Ordering information (INCH)	A Tube O.D		T Male NPT	C		D		W Hex. Flat	F		H		L	
	inch	mm	inch	inch	mm	inch	mm	inch	inch	mm	inch	mm	inch	mm
IP98TS04H04 TUBE 1/4X1/4	1/4	6.35	1/4	0.31	8	0.19	4.8	9/16	0.44	11.2	0.28	7.1	1.15	29.2
IP98TS04H06 TUBE 1/4X3/8	1/4	6.35	3/8	0.41	10.4	0.38	9.65	11/16	0.44	11.2	0.28	7.1	1.25	31.7
IP98TS06H06 TUBE 3/8X3/8	3/8	9.52	3/8	0.41	10.5	0.28	7.1	11/16	0.62	15.8	0.31	7.9	1.25	31.8
IP98TS06H04 TUBE 3/8X1/4	3/8	9.52	1/4	0.43	11	0.28	7.1	5/8	0.62	15.8	0.31	7.9	1.25	31.8
IP98TS06H08 TUBE 3/8X1/2	3/8	9.52	1/2	0.41	10.5	0.28	7.1	7/8	0.62	15.8	0.31	7.9	1.47	37.3
IP98TS08H06 TUBE 1/2X3/8	1/2	12.7	3/8	0.47	11.9	0.38	9.65	3/4	0.73	18.5	0.38	9.7	1.28	32.5
IP98TS04H08 TUBE 1/4X1/2	1/4	6.35	1/2	0.41	10.4	0.67	11.9	7/8	0.44	11.2	0.31	7.9	1.47	37.3
IP98TS08H08 TUBE 1/2X1/2S	1/2	12.7	1/2	0.47	12	0.41	10.4	7/8	0.73	18.5	0.38	9.7	1.53	38.9
IP98TS08H12 TUBE 1/2X3/4	1/2	12.7	3/4	0.47	11.9	0.41	10.4	1-1/16	0.75	19.05	0.5	12.7	1.61	41
IP98TS12H12 TUBE 3/4X3/4	3/4	19.05	3/4	0.47	11.9	0.62	15.75	1-1/16	1.05	26.7	0.44	11.2	1.56	39.6
IP98TS16H12 TUBE 1X3/4	1	25.4	3/4	0.56	14.2	0.62	15.75	1-3/8	1.36	34.5	0.62	15.7	1.78	45.14
IP98TS16H16 TUBE 1X1	1	25.4	1	0.56	14.2	0.86	21.8	1-3/8	1.36	34.5	0.62	15.7	1.97	50.04
IP98TS20H20 TUBE 1-1/4X1-1/4	1-1/4	31.75	1-1/4	0.66	16.9	1.09	27.7	1-3/4	1.73	44	0.75	19.2	2.18	55.5
IP98TS24H24 TUBE 1-1/2X1-1/2	1-1/2	38.1	1-1/2	0.71	18.1	1.34	34	2-1/8	1.97	50	0.90	22.9	2.44	62
IP98TS32H32 TUBE 2X2	2	50.8	2	1	25.4	1.81	45.97	2-3/4	2.53	63	1.19	30.4	3	76.2

## HAM-LET METAL HOSES COMPONENTS | FITTINGS

### MALE BSPP

IP98TS MG

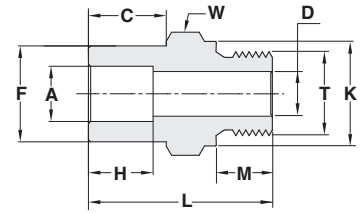

Ordering information (INCH)	A Tube O.D		T Male BSPP	C		D		W Hex. Flat	F		H		L		K		M	
	inch	mm	inch	inch	mm	inch	mm	inch	inch	mm	inch	mm	inch	mm	inch	mm	inch	mm
IP98TS04H04G 1/4X1/4 BSPP	1/4	6.35	1/4	0.41	10.4	0.19	4.8	3/4	0.48	12.2	0.28	7.1	1.19	30.2	0.71	18	0.44	11.2
IP98TS06H06G 3/8X3/8 BSPP	3/8	9.52	3/8	0.67	11.9	0.28	7.1	7/8	0.62	15.8	0.38	9.65	1.3	33	0.86	21.8	0.44	11.2
IP98TS08H08G 1/2X1/2 BSPP	1/2	12.7	1/2	0.67	11.9	0.41	10.4	1-1/16	0.73	18.5	0.38	9.7	1.47	37.4	1.02	26	0.56	14.2
IP98TS12H12G 3/4X3/4 BSPP	3/4	19.05	3/4	0.67	11.9	0.62	15.8	1-5/16	1.05	26.7	0.44	11.2	1.68	42.7	1.26	32	0.62	15.7
IP98TS16H16G 1X1 BSPP	1	25.4	1	0.56	14.2	0.78	19.8	1-5/8	1.36	34.5	0.75	19.2	1.88	47.75	1.53	39	0.72	18.3
IP98TS20H20G 1-1/4X1-1/4 BSPP	1-1/4	31.75	1-1/4	0.66	16.9	0.88	22.3	2-1/8	1.73	44	0.75	19.2	2.13	54.1	1.97	50	0.78	19.8
IP98TS24H24G 1-1/2X1-1/2 BSPP	1-1/2	38.1	1-1/2	0.71	18.1	1.24	31.6	2-1/4	1.97	50	0.9	22.9	2.49	63.25	2.16	55	0.87	22

### FEMALE NPT

IP96TS FP

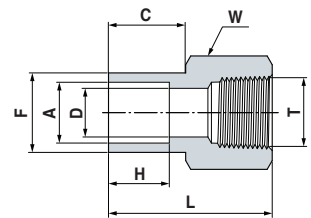

Ordering information (INCH)	A Tube O.D		T Female NPT	C		D		W Hex. Flat	F		H		L	
	inch	mm	inch	inch	mm	inch	mm	inch	inch	mm	inch	mm	inch	mm
IP96TS04H04 TUBE 1/4X1/4	1/4	6.35	1/4	0.39	10	0.19	4.8	3/4	0.49	12.40	0.28	7.1	1.18	30
IP96TS04H06 TUBE 3/8X3/8	3/8	9.52	3/8	0.41	10.5	0.28	7.1	7/8	0.62	15.8	0.28	6.95	1.19	30.4
IP96TS06H06 TUBE 3/8X1/4	3/8	9.52	1/4	0.41	10.5	0.28	7.1	3/4	0.62	15.8	0.31	7.9	1.24	31.5
IP96TS06H04 TUBE 1/2X1/2	1/2	12.7	1/2	0.46	11.9	0.41	10.4	1-1/16	0.73	18.5	0.38	9.7	1.59	40.4
IP96TS06H08 TUBE 3/4X3/4	3/4	19.05	3/4	0.46	11.9	0.62	15.7	1-5/16	1.04	26.4	0.44	11.2	1.72	43.9
IP96TS08H06 TUBE 1X1	1	25.4	1	0.55	14.2	0.88	22.3	1-5/8	1.36	34.5	0.61	15.7	1.95	49.53
IP96TS04H08 TUBE 1-1/2X1-1/2	1-1/2	38.1	1-1/2	0.71	18.1	1.34	34	2-3/8	1.97	50.0	0.90	22.9	2.43	61.73

## HAM-LET METAL HOSES COMPONENTS | FITTINGS

### FEMALE BSPP

IP96TS FG

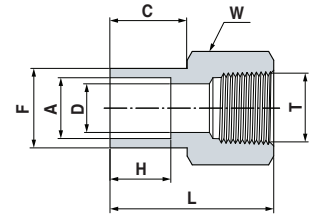

Ordering information (INCH)	A Tube O.D		T Female BSPP	C		D		W Hex. Flat	F		H		L	
	inch	mm		inch	mm	inch	mm		inch	mm	inch	mm	inch	mm
IP96TS04H04G 1/4X1/4BSPP	1/4	6.35	1/4	0.41	10.4	0.22	5.5	3/4	0.48	12.2	0.28	7.1	1.18	30.2
IP96TS06H06G 3/8X3/8BSPP	3/8	9.52	3/8	0.41	10.5	0.26	6.5	15/16	0.62	15.8	0.38	9.65	1.18	30.0
IP96TS08H08G 1/2X1/2BSPP	1/2	12.7	1/2	0.47	11.9	0.28	7.1	1-1/16	0.78	18.5	0.38	9.7	1.5	38.1

### TUBE BUTT WELD ADAPTER

IP93TBW BW

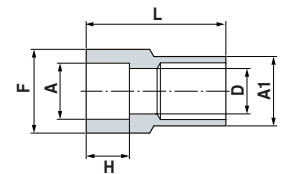

Ordering information (INCH)	A Tube O.D		A1		D		F		H		L	
	inch	mm	inch	mm	inch	mm	inch	mm	inch	mm	inch	mm
IP93TBW04H04 HOSE END	1/4	6.35	1/4	6.35	0.18	4.75	0.48	12.2	0.28	7.1	1.26	32.2
IP93TBW08H04 HOSE END	1/4	6.35	1/2	12.7	0.40	10.21	0.5	12.7	0.28	7.1	1.22	31.2
IP93TBW06H04 HOSE END	1/4	6.35	3/8	9.52	0.30	7.74	0.48	12.2	0.28	7.1	1.18	30.2
IP93TBW06H06 HOSE END	3/8	9.52	3/8	9.52	0.30	7.74	0.59	15.2	0.311	7.9	1.31	33.5
IP93TBW04H08 HOSE END	1/2	12.7	1/4	6.35	0.18	4.57	0.74	19	0.38	9.7	1.34	34.1
IP93TBW08H08 HOSE END	1/2	12.7	1/2	12.7	0.40	10.21	0.72	18.5	0.38	9.7	1.53	39.1
IP93TBW12H12 HOSE END	3/4	19.05	3/4	19.05	0.65	16.65	1.03	26.4	0.44	11.2	1.51	38.5
IP93TBW16H12 HOSE END	3/4	19.05	1	25.4	0.87	22.1	1.03	26.4	0.44	11.2	1.53	39
IP93TBW16H16 HOSE END	1	25.4	1	25.4	0.87	22.1	1.35	34.5	0.61	15.7	1.71	43.5
IP93TBW20H20 HOSE END	1-1/4	31.75	1-1/4	31.75	1.07	27.23	1.73	44	0.75	19.2	1.82	46.22
IP93TBW16H24 HOSE END	1-1/2	38.1	1	25.4	0.87	22.1	1.96	50	0.90	22.9	2.12	53.85
IP93TBW24H24 HOSE END	1-1/2	38.1	1-1/2	38.1	1.31	33.27	1.96	50	0.90	22.9	1.89	48
IP93TBW32H32 HOSE END	2	50.8	2	50.8	1.79	45.6	2.48	63	1.19	30.4	2.13	54.2



## HAM-LET METAL HOSES COMPONENTS | FITTINGS

### LONG BUTT WELD ADAPTER

IP93TBW LW

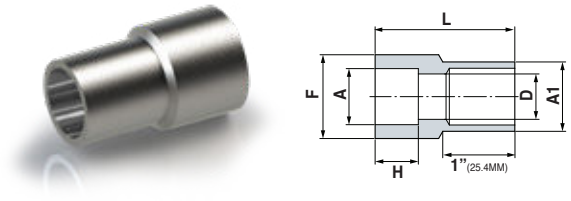

Ordering information (INCH)	A Tube O.D		A1		D		F		H		L	
	inch	mm	inch	mm	inch	mm	inch	mm	inch	mm	inch	mm
IP93TBW04H04 HOSE END L=1	1/4	6.35	1/4	6.35	0.18	4.57	0.48	12.2	0.28	7.1	1.52	38.6
IP93TBW06H06 HOSE END L=1	3/8	9.52	3/8	9.52	0.30	7.74	0.60	15.2	0.31	7.9	1.57	39.9
IP93TBW08H08 HOSE END L=1	1/2	12.7	1/2	12.7	0.40	10.21	0.73	18.5	0.38	9.7	1.79	45.5
IP93TBW12H12 HOSE END L=1	3/4	19.05	3/4	19.05	0.65	16.56	1.04	26.4	0.44	11.2	1.77	44.9
IP93TBW16H12 HOSE END L=1	3/4	19.05	1	25.4	0.87	22.1	1.04	26.4	0.44	11.2	1.79	45.4
IP93TBW16H24 HOSE END L=1	1-1/2	38.1	1	25.4	0.87	22.1	1.97	50.0	0.90	22.9	2.37	60.25

### MALE JIC 37° FLARE

748HFW

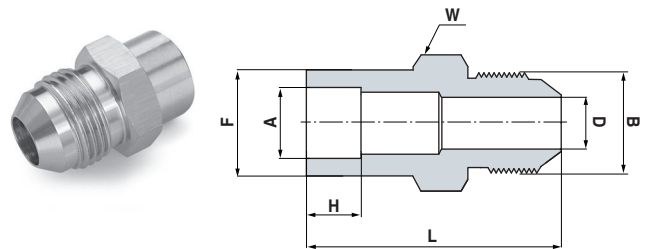

Ordering information (INCH)	A Tube O.D		B UN	D		F		H		L		W Hex flat
	inch	mm	inch	inch	mm	inch	mm	inch	mm	inch	mm	inch
748HFW _ 1/4 X 1/4	1/4	6.35	7/16-20	0.17	4.4	0.48	12.2	0.32	7.9	1.18	29.9	1/2
748HFW _ 3/8 X 3/8	3/8	9.52	9/16-18	0.29	7.5	0.62	15.8	0.39	9.65	1.28	32.45	5/8
748HFW _ 1/2 X 1/2	1/2	12.7	3/4-16	0.39	9.9	0.75	19.05	0.51	12.7	1.05	26.6	13/16
748HFW _ 3/4 X 3/4	3/4	19.05	1 1/16-12	0.60	15.5	1.05	26.7	0.57	14.2	1.78	45.2	1-1/8
748HFW _ 1 X 1	1	25.4	1 5/16-12	0.84	21.5	1.36	34.5	0.77	19.22	1.94	49.3	1-3/8
748HFW _ 1-1/4 X 1-1/4	1-1/4	31.75	1 5/8-12	1.07	27.5	1.73	44	0.77	19.2	2.15	54.5	1-3/4
748HFW _ 1-1/2 X 1-1/2	1-1/2	38.1	1 7/8-12	1.31	33	1.97	50	0.92	22.9	2.48	63	2-1/8
748HFW _ 2 X 2	2	50.8	2 1/2-12	1.78	45	2.48	63	1.22	30.4	3.07	77.9	2-5/8

# HAM-LET METAL HOSES COMPONENTS | FITTINGS

## MALE SWIVEL FACE SEAL

GM

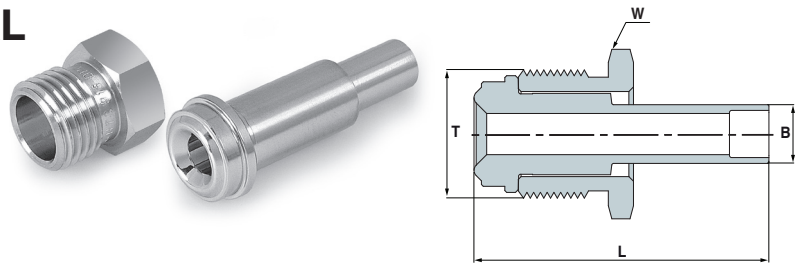

End Connection Type	Ordering information	Hose I.D. Weld pipe	End connection	T Thread-inch	W inch	L mm	B mm
Male Face Seal Swivel	V-GSW-1/4-W-H	1/4	1/4	9/6-18	5/8	33.3	8.9
	P-NM-1/4 NUT MALE						
Male Face Seal Swivel	V-GM-3/8-W-H	1/4	1/2	7/8-14	15/16	38.1	9.52
	P-NM-1/2 NUT MALE						
Male Face Seal Swivel	V-GM-1/2-W-H	3/8	1/2	7/8-14	15/16	38.1	12.7
	P-NM-1/2 NUT MALE						
Male Face Seal Swivel	V-GSW-1/2-W-H	1/2	1/2	7/8-14	15/16	38.1	15.1
	P-NM-1/2 NUT MALE						
Male Face Seal Swivel	P-GSW-3/4-W-H	3/4	3/4	1 1/4-18	1-5/16	50.8	22.3
	P-NM-3/4 NUT MALE						
Male Face Seal Swivel	P-GSW-1"-W-H	1	1	1 1/2-20	1-5/8	56.4	30.2
	P-NM-1 NUT MALE						

## FEMALE SWIVEL FACE SEAL

GF

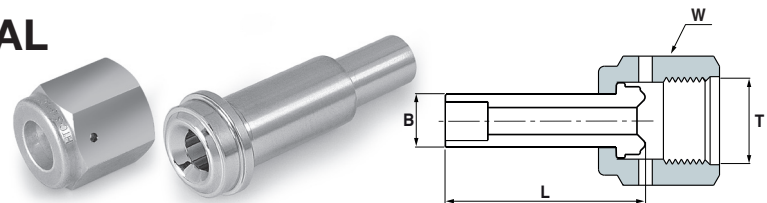

End Connection Type	Components Descriptions	Hose I.D. Weld pipe	Face seal	T Thread-inch	W inch	L mm	B mm
Female Face Seal Swivel	V-GSW-1/4-W-H	1/4	1/4	9/16-18	3/4	33.3	8.9
	P-NF-1/4 NUT FEMALE						
Female Face Seal Swivel	V-GM-3/8 -W-H	1/4	1/2	7/8-14	1-1/16	38.1	9.52
	P-NF-1/2 NUT FEMALE						
Female Face Seal Swivel	V-GM-1/2-W-H	3/8	1/2	7/8-14	1-1/16	38.1	12.7
	P-NF-1/2 NUT FEMALE						
Female Face Seal Swivel	V-GSW-1/2-W-H	1/2	1/2	7/8-14	1-1/16	38.1	15.1
	P-NF-1/2 NUT FEMALE						
Female Face Seal Swivel	P-GSW-3/4-W-H	3/4	3/4	1 1/4-18	1-1/2	50.8	22.3
	P-NF-3/4 NUT FEMALE						
Female Face Seal Swivel	P-GSW-1"-W-H	1	1	1 1/2-20	1-3/4	56.4	30.2
	P-NF-1 NUT FEMALE						
Female Face Seal Swivel	IP93TBW16H24 HOSE END	1 1/2	1	1 1/2-20	1-3/4	85.85	50
	P-GS-1"-W-H 0.065" W.T.						
	P-NF-1 NUT FEMALE						

## HAM-LET METAL HOSES COMPONENTS | FITTINGS

### FEMALE JIC 37° FLARE

746HFFW

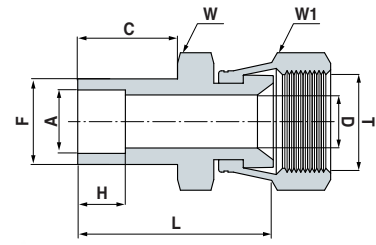

Ordering information (INCH)	A Tube O.D.		T Female Size	C		D		W Hex. Flat	W1 Hex. Flat	F		H		L	
	inch	mm	inch	inch	mm	inch	mm	inch	inch	inch	mm	inch	mm	inch	mm
746HFFW_ 1/4 X 1/4	1/4	6.35	7/16-20	0.39	10	0.17	4.4	1/2	9/16	0.49	12.40	0.27	7.1	0.90	22.86
746HFFW_ 3/8 X 3/8	3/8	9.52	9/16-18	0.41	10.5	0.27	7.1	5/8	11/16	0.62	15.8	0.37	9.65	1.09	27.69
746HFFW_ 1/2 X 1/2	1/2	12.7	3/4.-16	0.46	11.9	0.38	9.9	13/16	7/8	0.73	18.5	0.38	9.7	1.19	30.23
746HFFW_ 3/4 X 3/4	3/4	19.05	1-1/16-12	0.46	11.9	0.61	15.5	1-1/16	1-1/4	1.04	26.4	0.44	11.2	1.32	33.53
746HFFW_ 1 X 1	1	25.4	1-5/16-12	0.55	14.2	0.84	21.5	1-3/8	1-1/2	1.36	34.5	0.61	15.7	1.61	40.9
746HFFW_ 2 X 2	2	50.8	-	-	-	-	-	-	-	-	-	-	-	-	-

### SANITARY FLANGE

768SFLW

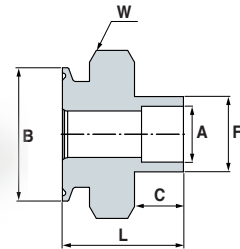

Ordering information (INCH)	A Tube O.D.		B Flange size	C		W Hex. Flat	F		L	
	inch	mm	inch	inch	mm	inch	inch	mm	inch	mm
768SFLW_ 1/2 X 1/2	1/2	12.7	1/2	0.47	11.94	-	0.75	19.05	1.34	34.13
768SFLW_ 3/4 X 3/4	3/4	19.05	3/4	0.47	11.94	-	1.05	26.7	1.34	34.14
768SFLW_ 1 X 1	1	25.4	1	0.56	14.22	-	1.36	34.5	1.44	36.63
768SFLW_ 1 1/2 X 1 1/2	1-1/2	38.1	1-1/2	0.71	18.1	-	1.97	50	1.65	41.8
768SFLW_ 2 X 2	2	50.8	2	1	25.4	-	2.48	63	2.46	62.51

## HAM-LET METAL HOSES COMPONENTS | FITTINGS

### PRESWAGED TUBE ADAPTER

739LW

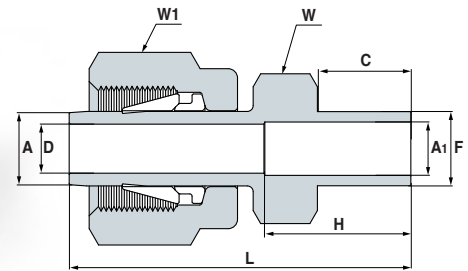

Ordering information (INCH)	A Tube O.D		A1 Tube O.D		C		D		W Hex. Flat		F		H		L		W1 Hex. Flat
	inch	mm	inch	mm	inch	mm	inch	mm	inch	mm	inch	mm	inch	mm	inch	mm	inch
739LW _ 1/4 X 3/8 PRSW	1/4	6.35	3/8	9.52	0.47	11.9	0.17	4.2	5/8	0.62	15.8	0.38	9.7	1.35	34.3	9/16	
739LW _ 3/8 X 3/8 PRSW	3/8	9.52	3/8	9.52	0.47	11.9	0.28	7.11	5/8	0.62	15.8	0.38	9.7	1.42	36.7	11/16	
739LW _ 1/2 X 1/2 PRSW	1/2	12.7	1/2	12.7	0.47	11.9	0.39	9.91	13/16	0.75	19.05	0.5	12.7	1.67	42.42	7/8	
739LW _ 3/4 X 3/4 PRSW	3/4	19.05	3/4	19.05	0.47	11.9	0.59	15	1-1/16	1.05	26.7	0.56	14.2	1.73	43.94	1-1/8	
739LW _ 1 X 3/4 PRSW	1	25.4	3/4	19.05	0.74	11.9	0.8	20.3	1-1/16	1.05	26.7	0.56	14.2	2.12	54	1-1/2	
739LW _ 1 X 1 PRSW	1	25.4	1	25.4	0.74	11.9	0.8	20.3	1-3/8	1.36	34.5	0.76	19.2	2.33	59.2	1-1/2	

Ordering information (METRIC)	A Tube O.D		A1 Tube O.D		C	D	W Hex. Flat		F	H	L	W1 Hex. Flat	
	mm	inch	mm	inch	mm	mm	inch	MM	mm	mm	mm	mm	inch
739LW _ 6MMX 1/4 PRSW	6	1/4	10.4	4	10.4	4	1/2	-	11.2	7.9	31.7	14	-
739LW _ 8MM X 1/4 PRSW	8	1/4	10.4	5.6	10.4	5.6	-	14	11.2	7.9	35.3	16	-
739LW _ 10MMX 3/8 PRSW	10	3/8	11.9	7.1	11.9	7.1	5/8	-	15.8	9.7	36	-	3/4
739LW _ 12MM X 1/2 PRSW	12	1/2	11.9	8.8	11.9	8.8	13/16	-	19.05	12.7	42.5	22	-
739LW _ 18MM X 3/4 PRSW	18	3/4	11.9	13.9	11.9	13.9	-	27	26.7	14.2	46.2	30	-
739LW _ 25MM X 1 PRSW	25	1	11.9	19.8	11.9	19.8	-	35	34.5	19.2	58.7	-	1.1/2



# HAM-LET PTFE HOSES

## COMPONENTS



# Bulk PTFE Hoses

## HOW TO ORDER

Line		Hoses		Series		Configuration		Tube ID		Bulk Hoses		Options	
<b>T</b>	PTFE	<b>H</b>	Hose	<b>T</b>	Smooth PTFE Core	<b>None</b>	SS 304 single braid	<b>02</b>	1/8	<b>M</b>	Meter	<b>C</b>	Conductive Carbon Lining
		<b>S</b>	Silicon Covered	<b>0</b>	Without braid			<b>04</b>	1/4				
		<b>C</b>	Convolute PTFE Core	<b>1</b>	SS 316 single braid			<b>06</b>	3/8				
		<b>B</b>	Smooth core fiber braid	<b>2</b>	SS 304 double braid			<b>08</b>	1/2				
		<b>R</b>	Smooth core additional fiber braid					<b>12</b>	3/4				
		<b>P</b>	Silicon cover smooth core					<b>16</b>	1				
		<b>N</b>	Convolute core insulating wrap					<b>24</b>	1 1/2				
								<b>32</b>	2				

OPTIONAL



For a complete range of end connections see the following pages, or the Ham-Let catalogue.

### Warning!

The system designer and user have the sole responsibility for selecting products suitable for their special application requirements, ensuring their safe and trouble-free installation, operation, and maintenance. Application details, material compatibility and product ratings should all be considered for each selected product. Improper selection, installation or use of products can cause property damage or personal injury.



## HAM-LET PTFE HOSES COMPONENTS | FITTINGS

### LET-LOK 130 LHT

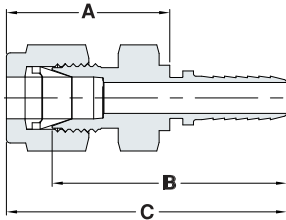

Ordering Information	Hose I.D.	Tube Size	B		C		A	
			inch	mm	inch	mm	inch	mm
<b>INCH</b>								
130LHT _ 1/8 X 1/8 SP	1/8	1/8	1.19	30.30	1.57	39.90	0.90	22.90
130LHT _ 1/4 X 1/4 SP	1/4	1/4	1.44	36.70	1.73	44.05	1.02	25.80
130LHT _ 3/8 X 3/8 SP	3/8	3/8	1.70	43.20	1.99	50.60	1.09	27.80
130LHT _ 1/2 X 1/2 SP	1/2	1/2	1.94	49.30	2.34	59.50	1.23	31.20
130LHT _ 3/4 X 1/2 SP	1/2	3/4	2.03	51.60	2.43	61.80	1.32	33.45
130LHT _ 3/4 X 3/4 SP	3/4	3/4	2.25	57.15	2.65	67.30	1.28	32.40
130LHT _ 1 X 1 SP	1	1	2.54	64.50	3.02	76.70	1.47	37.45
130LHT _ 1-1/2 X 1-1/2 SP	1-1/2	1-1/2	3.92	99.60	4.99	126.80	2.47	62.75
<b>METRIC</b>								
130LHT _ 3MM X 1/8 SP	1/8	3mm	1.18	30.00	1.45	36.90	0.90	22.90
130LHT _ 6MM X 1/4 SP	1/4	6mm	1.44	36.70	1.74	44.10	1.02	25.80
130LHT _ 8MM X 1/4 SP	1/4	8mm	1.45	36.90	1.75	44.40	1.03	26.15
130LHT _ 10MM X 3/8 SP	3/8	10mm	1.71	43.50	2.01	51.10	1.12	28.40
130LHT _ 12MM X 1/2 SP	1/2	12mm	1.94	49.30	2.34	59.40	1.22	31.10
130LHT _ 18MM X 3/4 SP	3/4	18mm	2.25	57.15	2.65	67.25	1.16	29.35
130LHT _ 25MM X 1 SP	1	25mm	2.70	68.55	3.19	80.90	1.64	41.65
130LHT _ 38MM X 1-1/2 SP	1-1/2	38mm	4.02	102.00	5.10	129.60	2.83	71.90

### TUBE ADAPTER 130 LTT

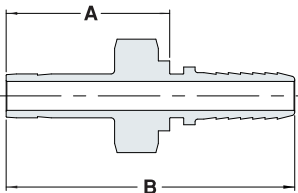

Ordering Information	Hose I.D.	Tube Size	B		A	
			inch	mm	inch	mm
<b>INCH</b>						
130LTT _ 1/8 X 1/8 SP	1/8	1/8	1.37	34.80	0.82	20.80
130LTT _ 1/4 X 1/8 SP	1/8	1/4	1.51	38.30	0.96	24.30
130LTT _ 1/4 X 1/4 SP	1/4	1/4	1.65	41.90	0.93	23.63
130LTT _ 3/8 X 3/8 SP	3/8	3/8	1.93	48.90	1.03	26.20
130LTT _ 3/8 X 1/2 SP	1/2	3/8	2.17	55.10	1.06	26.80
130LTT _ 1/2 X 1/2 SP	1/2	1/2	2.38	60.55	1.27	32.25
130LTT _ 3/4 X 1/2 SP	1/2	3/4	2.52	64.00	1.41	35.70
130LTT _ 3/4 X 3/4 SP	3/4	3/4	2.76	70.00	1.38	35.10
30LTT _ 5/8 X 5/8 SP	5/8	5/8	2.54	64.60	1.39	35.25
130LTT _ 3/4 X 1 SP	1	3/4	2.95	75.00	1.41	35.75
130LTT _ 1 X 3/4 SP	3/4	1	3.08	78.30	1.71	43.40
130LTT _ 1 X 1 SP	1	1	3.28	83.30	1.73	44.05
130LTT _ 1-1/2 X 1-1/2 SP	1-1/2	1-1/2	5.35	136.00	3.08	78.30
<b>METRIC</b>						
130LTT _ 3MM X 1/8 SP	1/8	3mm	1.37	34.80	0.82	20.80
130LTT _ 6MM X 1/4 SP	1/4	6mm	1.68	42.70	0.96	24.45
130LTT _ 8MM X 1/4 SP	1/4	8mm	1.71	43.50	0.99	25.25
130LTT _ 10MM X 3/8 SP	3/8	10mm	1.89	48.00	0.90	22.75
130LTT _ 12MM X 1/2 SP	1/2	12mm	2.39	60.70	1.28	32.40
130LTT _ 18MM X 1/2 SP	1/2	18mm	2.52	64.00	1.41	35.70
130LTT _ 18MM X 3/4 SP	3/4	18mm	2.76	70.00	1.38	35.10
130LTT _ 25MM X 1 SP	1	25mm	3.44	87.30	1.91	48.50
130LTT _ 38MM X 1-1/2 SP	1 1/2	38mm	5.35	136.00	3.08	78.30

## HAM-LET PTFE HOSES COMPONENTS | FITTINGS

### MALE NPT 130 HMTH

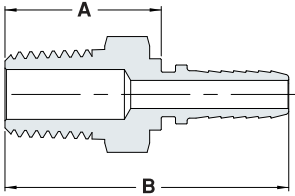

Ordering Information	Hose I.D.	Male NPT	B		A	
			inch	mm	inch	mm
130HMTH _ 1/8 X 1/8 SP	1/8	1/8	1.25	31.70	0.70	17.70
130HMTH _ 1/4 X 1/4 SP	1/4	1/4	1.60	40.55	0.88	22.40
130HMTH _ 1/4 X 3/8 SP	3/8	1/4	1.81	45.90	0.91	23.15
130HMTH _ 1/4 X 1/2 SP	1/2	1/4	2.04	51.80	0.93	23.50
130HMTH _ 3/8 X 3/8 SP	3/8	3/8	1.80	45.60	0.90	22.87
130HMTH _ 3/8 X 1/2 SP	1/2	3/8	2.04	51.80	0.93	23.50
130HMTH _ 1/2 X 1/2 SP	1/2	1/2	2.22	56.45	1.11	28.15
130HMTH _ 1/2 X 3/4 SP	3/4	1/2	2.51	63.65	1.13	28.70
130HMTH _ 3/4 X 3/4 SP	3/4	3/4	2.51	63.65	1.13	28.70
130HMTH _ 3/4 X 1 SP	1	3/4	2.72	69.10	1.18	29.85
130HMTH _ 1 X 1 SP	1	1	2.92	74.05	1.37	34.80
130HMTH _ 1-1/2 X 1-1/2 SP	1-1/2	1-1/2	4.24	107.80	1.97	50.10
130HMTH _ 2 X 2 SP	2	2	4.73	120.25	2.02	51.30

### MALE BSP-P 130 HMTHG

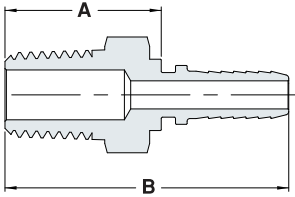

Ordering Information	Hose I.D.	Male BSPP	B		A	
			inch	mm	inch	mm
130HMTHG _ 1/8 X 1/8 SP	1/8	1/8	1.20	30.60	0.65	16.60
130HMTHG _ 1/4 X 1/4 SP	1/4	1/4	1.63	41.40	0.92	23.25
130HMTHG _ 1/4 X 3/8 SP	3/8	1/4	1.80	45.80	0.91	23.10
130HMTHG _ 1/4 X 1/2 SP	1/2	1/4	2.06	52.30	0.94	24.00
130HMTHG _ 3/8 X 3/8 SP	3/8	3/8	1.78	45.10	0.88	22.40
130HMTHG _ 3/8 X 1/2 SP	1/2	3/8	2.03	51.60	0.93	23.50
130HMTHG _ 1/2 X 1/2 SP	1/2	1/2	2.15	54.70	1.04	26.50

## HAM-LET PTFE HOSES COMPONENTS | FITTINGS

### FEMALE NPT 130 HFTH

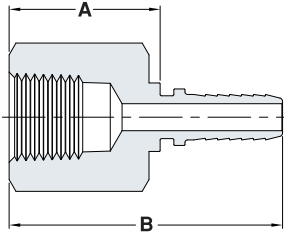

Ordering Information	Hose I.D.	Female NPT	B		A	
			inch	mm	inch	mm
130HFTH _ 1/8 X 1/8 SP	1/8	1/8	1.18	30.00	0.63	16.00
130HFTH _ 1/4 X 1/4 SP	1/4	1/4	1.60	40.55	0.88	22.40
130HFTH _ 1/4 X 3/8 SP	3/8	1/4	1.78	45.30	0.89	22.55
130HFTH _ 3/8 X 3/8 SP	3/8	3/8	1.78	45.30	0.89	22.55
130HFTH _ 1/2 X 1/2 SP	1/2	1/2	2.23	56.70	1.12	28.40
130HFTH _ 3/4 X 3/4 SP	3/4	3/4	2.51	63.80	1.14	28.90
130HFTH _ 1 X 1 SP	1	1	3.08	78.20	1.55	39.25
130HFTH _ 1-1/2 X 1-1/2 SP	1-1/2	1-1/2	3.87	98.25	1.60	40.55

### FEMALE BSP-P 130 HFTHG

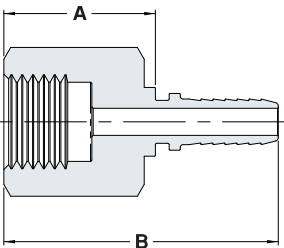

Ordering Information	Hose I.D.	Female BSP-P	B		A	
			inch	mm	inch	mm
130HFTHG _ 1/8 X 1/8 SP	1/8	1/8	1.28	32.40	0.72	18.40
130HFTHG _ 1/4 X 1/4 SP	1/4	1/4	1.60	40.55	0.88	22.40
130HFTHG _ 3/8 X 3/8 SP	3/8	3/8	1.72	43.75	0.83	21.00
130HFTHG _ 1/2 X 1/2 SP	1/2	1/2	2.25	57.10	1.13	28.80
130HFTHG _ 3/4 X 3/4 SP	3/4	3/4	2.54	64.60	1.17	29.70
130HFTHG _ 1 X 1 SP	1	1	3.08	78.20	1.54	39.00

## HAM-LET PTFE HOSES COMPONENTS | FITTINGS

### BUTT WELD ADAPTER 130 HBWTH

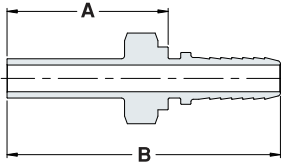

Ordering Information	Hose I.D.	Tube Size	B		A	
			inch	mm	inch	mm
130HBWTH _ 1/4 X 1/4	1/4	1/4	1.74	44.20	1.02	25.95
130HBWTH _ 3/8 X 3/8	3/8	3/8	1.95	49.50	1.05	26.75
130HBWTH _ 1/2 X 1/2	1/2	1/2	2.22	56.45	1.11	28.15
130HBWTH _ 1/2 X 3/4	1/2	3/4	2.22	56.45	1.11	28.15
130HBWTH _ 3/4 X 3/4	3/4	3/4	2.51	63.65	1.13	28.70
130HBWTH _ 1 X 3/4	1	3/4	2.73	69.30	1.18	30.05
130HBWTH _ 1 X 1	1	1	2.73	69.30	1.18	30.05
130HBWTH _ 1-1/2 X 1-1/2	1-1/2	1-1/2	3.96	100.70	2.27	57.70

### FEMALE FACE SEAL SWIVEL 130 FHC

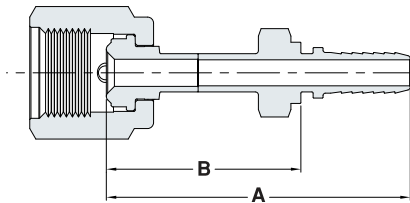

Ordering Information	Hose I.D.	Face Seal	B		A	
			inch	mm	inch	mm
130FHC _ 1/4 x 1/4	1/4	1/4	1.27	32.23	1.98	50.40
130FHC _ 3/8 x 3/8	3/8	3/8	1.67	42.50	2.57	65.25
130FHC _ 1/2 x 1/2	1/2	1/2	1.73	43.90	2.84	72.20
130FHC _ 3/4 x 3/4	1/2	3/4	2.25	57.10	3.36	85.41
130FHC _ 1 x 3/4	1	3/4	2.32	59.05	3.87	98.30
130FHC _ 1 x 1	1	1	2.44	62.05	3.99	101.30

## HAM-LET PTFE HOSES COMPONENTS | FITTINGS

### Male JIC 37° flare 130HFLTH

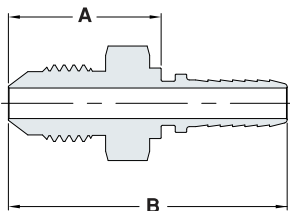

Ordering Information	Hose I.D.	Face Seal	B		A	
			inch	mm	inch	mm
130HFLTH _ 1/8 X 1/8 MALE	1/8	1/8	1.37	34.80	0.82	20.85
130HFLTH _ 1/4 X 1/4 MALE	1/4	1/4	1.58	40.15	0.86	21.90
130HFLTH _ 3/8 X 3/8 MALE	3/8	3/8	1.81	46.10	1.06	27.03
130HFLTH _ 1/2 X 1/2 MALE	1/2	1/2	2.18	55.25	1.06	26.95
130HFLTH _ 3/4 X 3/4 MALE	3/4	3/4	2.77	70.45	1.40	35.55
130HFLTH _ 1 X 1 MALE	1	1	3.08	78.20	1.53	38.95
130HFLTH _ 1-1/2X1-1/2MALE	1-1/2	1-1/2	4.19	106.35	1.92	48.65

### Female JIC 37° flare 130HFLTHF

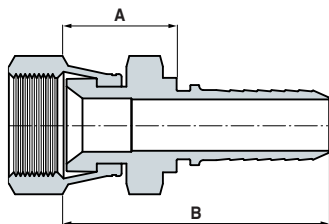

Ordering Information	Hose I.D.	Tube Size	B		A	
			inch	mm	inch	mm
130HFLTHF _ 1/8 X 1/8 FEMALE	1/8	1/8	-	-	-	-
130HFLTHF _ 1/4 X 1/4 FEMALE	1/4	1/4	1.31	33.15	0.59	14.90
130HFLTHF _ 3/8 X 3/8 FEMALE	3/8	3/8	1.58	40.20	0.69	17.45
130HFLTHF _ 1/2 X 1/2 FEMALE	1/2	1/2	1.92	48.70	0.80	20.40
130HFLTHF _ 3/4 X 3/4 FEMALE	3/4	3/4	2.23	56.60	0.85	21.70
130HFLTHF _ 1 X 1 FEMALE	1	1	2.68	68.00	1.13	28.75
130HFLTHF _ 1-1/2X1-1/2 FEMALE	1-1/2	1 -1/2	3.89	98.80	1.62	41.10

## HAM-LET PTFE HOSES COMPONENTS | FITTINGS

### MALE BSP-T 130 HMTHR

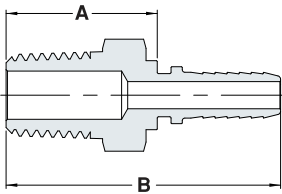

Ordering Information	Hose I.D.	Male BSPT	B		A	
			inch	mm	inch	mm
130HMTHR _ 1/8 X 1/8	1/8	1/8	1.25	31.75	0.70	17.80
130HMTHR _ 1/4 X 1/4	1/4	1/4	1.59	40.30	0.87	22.05
130HMTHR _ 3/8 X 3/8	3/8	3/8	1.77	45.05	0.88	22.30
130HMTHR _ 1/2 X 1/2	1/2	1/2	2.28	57.90	1.17	29.60
130HMTHR _ 3/4 X 3/4	3/4	3/4	2.60	66.05	1.22	31.10
130HMTHR _ 1 X 1	1	1	3.08	78.20	1.54	39.00
130HMTHR _ 1-1/2 X 1-1/2	1-1/2	1-1/2	4.24	107.70	1.97	50.00

### FEMALE BSP-T 130 HFTHR

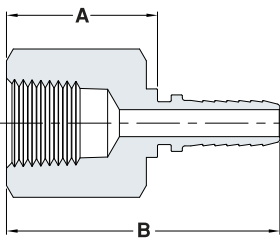

Ordering Information	Hose I.D.	Female BSPT	B		A	
			inch	mm	inch	mm
130HFTHR _ 1/8 X 1/8	1/8	1/8	1.18	29.95	0.63	16.00
130HFTHR _ 1/4 X 1/4	1/4	1/4	1.51	38.30	0.79	20.05
130HFTHR _ 3/8 X 3/8	3/8	3/8	1.74	44.30	0.85	21.55
130HFTHR _ 1/2 X 1/2	1/2	1/2	2.19	55.60	1.07	27.30
130HFTHR _ 3/4 X 3/4	3/4	3/4	2.51	63.75	1.14	28.85
130HFTHR _ 1 X 1	1	1	3.08	78.20	1.54	39.00
130HFTHR _ 1-1/2 X 1-1/2	1-1/2	1-1/2	-	-	-	-

## HAM-LET PTFE HOSES COMPONENTS | FITTINGS

### TUBE ADAPTER PRESWAGED 130 LTT PRSW

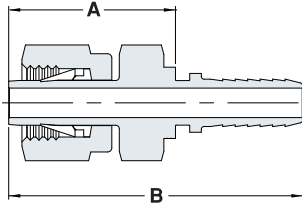

Ordering Information	Hose I.D.	Tube Size	B		A		
			inch	mm	inch	mm	
<b>INCH</b>							
130LTT _ 1/4X1/4PRSW SP	1/4	1/4	1.65	41.90	0.93	23.63	
130LTT _ 3/8X3/8PRSW SP	3/8	3/8	1.93	48.90	1.03	26.20	
130LTT _ 3/8X1/2PRSW SP	1/2	3/8	2.17	55.10	1.06	26.80	
130LTT _ 1/2X1/2PRSW SP	1/2	1/2	2.38	60.55	1.27	32.25	
130LTT _ 3/4X3/4PRSW SP	3/4	3/4	2.76	70.00	1.38	35.10	
130LTT _ 1"X1"PRSW SP	1	1	3.28	83.30	1.73	44.05	
<b>METRIC</b>							
130LTT _ 6MMX1/4PRSW SP	1/4	6mm	1.68	42.70	0.96	24.45	
130LTT _ 8MMX1/4PRSW SP	1/4	8mm	1.71	43.50	0.99	25.25	
130LTT _ 10MMX3/8PRSW SP	3/8	10mm	1.89	48.00	0.90	22.75	
130LTT _ 12MMX1/2PRSW SP	1/2	12mm	2.39	60.70	1.28	32.40	
130LTT _ 18MMX1/2PRSW SP	1/2	18mm	2.52	64.00	1.41	35.70	
130LTT _ 18MMX3/4PRSWSP	3/4	18mm	2.76	70.00	1.38	35.10	
130LTT _ 25MMX1PRSW SP	1	25mm	3.44	87.30	1.91	48.50	

### SANITARY FLANGE 130 SF

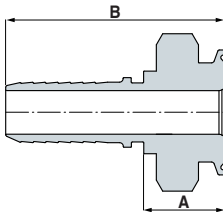

Ordering Information	Hose I.D.	Flange size	B		A		
			inch	mm	inch	mm	
<b>INCH</b>							
130SF _ 1/2X1/2	1/2	1/2	2.09	53.05	0.97	24.75	
130SF _ 3/4X3/4	3/4	3/4	2.35	59.65	0.97	24.75	
130SF _ 1X1	1	1	2.55	64.83	1.01	25.60	
130SF _ 1-1/2X1-1/2	1-1/2	1-1/2	3.70	94.10	1.43	36.40	



## HAM-LET PTFE HOSES COMPONENTS | FITTINGS

### CRIMP RING FOR SMOOTH PTFE CORE HOSES

THT \_ CRMP

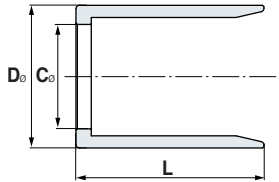

Ordering Information	L		C		D	
	inch	mm	Inch	mm	Inch	mm
THT02-CRMP	-	-	-	-	-	-
THT04-CRMP	0.89	22.60	0.33	8.50	0.62	15.80
THT06-CRMP	0.75	19.15	0.44	11.05	0.67	17.10
THT08-CRMP	1.06	27.00	0.59	15.00	0.81	20.50
THT12-CRMP	1.40	35.50	0.88	22.40	1.16	29.50
THT16-CRMP	1.55	39.30	1.15	29.30	1.48	37.70
THT24-CRMP	-	-	-	-	-	-
THT32-CRMP	-	-	-	-	-	-

### CRIMP RING FOR CONVOLUTED PTFE CORE HOSES

THC \_ CRMP

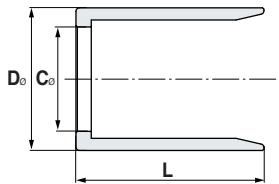

Ordering Information	L		C		D	
	inch	mm	Inch	mm	Inch	mm
THC02-CRMP-HD	-	-	-	-	-	-
THC04-CRMP-HD	-	-	-	-	-	-
THC06-CRMP-HD	9.06	23.00	5.47	13.90	8.86	22.60
THC08-CRMP-HD	11.5	29.20	6.18	15.70	7.64	19.40
THC12-CRMP-HD	-	-	-	-	-	-
THC16-CRMP-HD	-	-	-	-	-	-
THC24-CRMP-HD	-	-	-	-	-	-
THC32-CRMP-HD	-	-	-	-	-	-

# **HAM-LET** RUBBER HOSES COMPONENTS



# HAM-LET RUBBER HOSES COMPONENTS | FITTINGS

## BULK RUBBER HOSES

Available for ordering as:

- cut length up to 150 feet (50 meter)
- Reel of fix length 500 feet (152.4 meter) for all sizes (maximum 4 pieces in a reel, 10' minimum)

## HOW TO ORDER

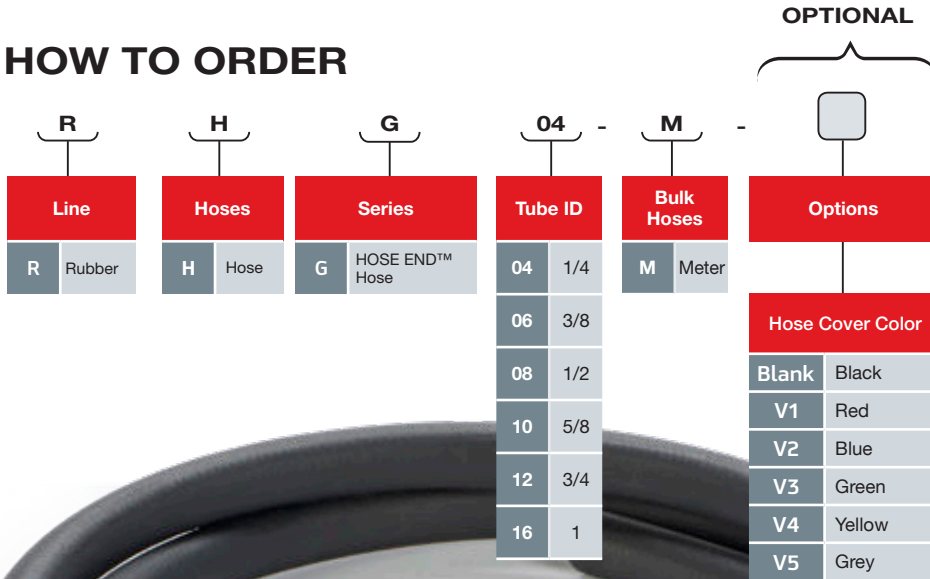

For a complete range of end connections see the following pages, or the Ham-Let catalogue.

### Warning!

The system designer and user have the sole responsibility for selecting products suitable for their special application requirements, ensuring their safe and trouble-free installation, operation, and maintenance. Application details, material compatibility and product ratings should all be considered for each selected product. Improper selection, installation or use of products can cause property damage or personal injury.

# HAM-LET RUBBER HOSES COMPONENTS | FITTINGS

## LET-LOK® TUBE FITTINGS 130 LHPO / 130 LHPOP

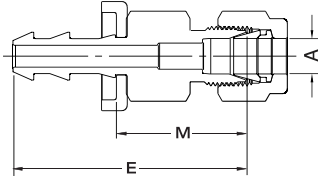

Ordering Information	Hose I.D.	A Tube O.D.	E		M	
			inch	mm	inch	mm
<b>PO INCH</b>						
130LHPO _ 1/4 X 1/4	1/4	1/4	1.97	42.67	1.14	23.92
130LHPO _ 3/8 X 3/8	3/8	3/8	2.11	46.22	1.17	24.52
130LHPO _ 1/2 X 1/2	1/2	1/2	2.47	52.58	1.37	26.68
130LHPO _ 3/4 X 3/4	3/4	3/4	2.96	65.05	1.32	23.3
130LHPO _ 1 X 1	1	1	3.01	64.36	1.6	28.36
<b>PO INCH TO MM</b>						
130LHPO _ 1/4 X 6MM	1/4	6mm	1.97	10.64	1.14	6.16
130LHPO _ 1/4 X 8MM	1/4	8mm	1.97	10.64	1.14	6.16
130LHPO _ 3/8 X 6MM	3/8	8mm	-	-	-	-
130LHPO _ 3/8 X 8MM	3/8	10mm	-	-	-	-
130LHPO _ 1/2 X 12MM	1/2	12mm	2.47	13.34	1.45	7.83
130LHPO _ 3/4 X 18MM	3/4	18mm	-	-	-	-
130LHPO _ 1 X 25MM	1	25mm	-	-	-	-

Ordering Information	Hose I.D.	A Tube O.D.	E		M	
			inch	mm	inch	mm
<b>POP INCH</b>						
130LHPOP _ 1/4 X 1/4	1/4	1/4	1.43	36.20	0.70	17.70
130LHPOP _ 3/8 X 3/4	3/8	3/4	2.38	60.50	0.97	24.60
130LHPOP _ 3/4 X 3/4	3/4	3/4	2.39	60.65	0.97	24.65

## UNIONS 132 PO

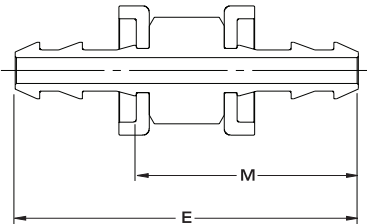

Ordering Information	Hose I.D.	Hose I.D.	E		M	
			inch	mm	inch	mm
<b>PO</b>						
132PO _ 1/4 X 1/4	1/4	1/4	2.07	52.6	1.33	33.85
132PO _ 3/8 X 3/8	3/8	3/8	2.25	57.2	1.4	35.5
132PO _ 1/2 X 1/2	1/2	1/2	2.61	66.3	1.59	40.4
132PO _ 3/4 X 3/4	3/4	3/4	3.82	97.1	2.18	55.35
132PO _ 1 X 1	1	1	3.57	90.8	2.16	54.8

## HAM-LET RUBBER HOSES COMPONENTS | FITTINGS

### MALE PIPE THREADS 130 HMPO / 130 HMPOP

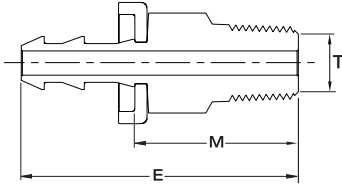

Ordering Information	Hose I.D.	T NPT	E		M		
			inch	mm	inch	mm	
<b>PO NPT</b>							
130HMPO _ 1/4 X 1/4	1/4	1/4	1.68	42.7	0.94	23.95	
130HMPO _ 1/4 X 3/8	1/4	3/8	1.69	43.0	0.95	24.25	
130HMPO _ 3/8 X 1/4	3/8	1/4	1.80	45.7	0.94	24.0	
130HMPO _ 3/8 X 3/8	3/8	3/8	1.80	45.7	0.94	24.0	
130HMPO _ 3/8 X 1/2	3/8	1/2	2.02	51.2	1.16	29.5	
130HMPO _ 1/2 X 3/8	1/2	3/8	2.02	51.34	1.0	25.44	
130HMPO _ 1/2 X 1/2	1/2	1/2	2.19	55.6	1.17	29.7	
130HMPO _ 1/2 X 3/4	1/2	3/4	2.21	56.14	1.19	30.24	
130HMPO _ 3/4 X 1/2	3/4	1/2	2.81	71.4	1.17	29.65	
130HMPO _ 3/4 X 3/4	3/4	3/4	2.81	71.4	1.17	29.65	
130HMPO _ 1 X 1	1	1	2.99	76.06	1.58	40.06	
<b>POP NPT</b>							
130HMPOP _ 1/4X1/4	1/4	1/4	1.57	40.1	0.82	21.6	
130HMPOP _ 1/4X1/2	1/4	1/2	1.9	48.3	1.17	29.8	
130HMPOP _ 3/8X1/4	3/8	1/4	1.78	45.0	0.88	22.75	
130HMPOP _ 3/8X3/8	3/8	3/8	1.78	45.3	0.9	23.05	
130HMPOP _ 1/2X3/8	1/2	3/8	1.93	49.0	0.9	22.9	
130HMPOP _ 1/2X1/2	1/2	1/2	2.18	55.5	1.16	29.4	
130HMPOP _ 1/2X3/4	1/2	3/4	2.23	56.6	1.2	30.5	
130HMPOP _ 3/4X1/2	3/4	1/2	2.61	66.4	1.2	30.5	
130HMPOP _ 3/4X3/4	3/4	3/4	2.61	66.4	1.2	30.5	
130HMPOP _ 1 X 1	1	1	3.06	78.0	1.66	42.1	

### MALE PIPE THREADS 130 HMRPO / 130 HMRPOP

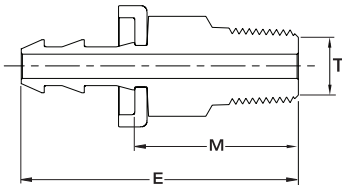

Ordering Information	Hose I.D.	T ISO	E		M		
			inch	mm	inch	mm	
<b>BSP Tapered</b>							
130HMRPO _ 3/8 X 3/8	3/8	3/8	1.8	45.7	0.94	24.0	
130HMRPO _ 1/2 X 1/2	1/2	1/2	2.19	55.6	1.17	29.7	
130HMRPO _ 3/4 X 1/2	3/4	1/2	2.81	71.4	1.17	29.65	
130HMRPO _ 3/4 X 3/4	3/4	3/4	2.81	71.4	1.17	29.65	

## HAM-LET RUBBER HOSES COMPONENTS | FITTINGS

### TUBE ADAPTER 131 PO / 131 POP

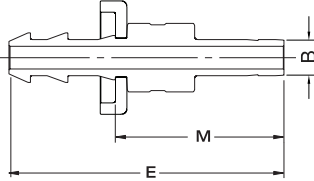

Ordering Information	Hose I.D.	B Tube O.D.	E		M	
			inch	mm	inch	mm
<b>PO INCH</b>						
131PO _ 1/4 X 1/4	1/4	1/4	1.91	48.5	1.17	29.75
131PO _ 3/8 X 1/4	3/8	1/4	1.95	49.6	1.10	27.9
131PO _ 3/8 X 3/8	3/8	3/8	2.02	51.3	1.17	29.6
131PO _ 1/2 X 3/8	1/2	3/8	2.25	57.14	1.23	31.24
131PO _ 1/2 X 1/2	1/2	1/2	2.47	62.74	1.45	36.84
131PO _ 3/4 X 1/2	3/4	1/2	3.04	77.1	1.39	35.35
131PO _ 3/4 X 3/4	3/4	3/4	3.14	79.8	1.50	38.05
131PO _ 1 X 3/4	1	3/4	3.06	77.7	1.64	41.7
131PO _ 1 X 1	1	1	3.39	86.0	1.97	50.0
<b>PO MM</b>						
131PO _ 1/4 X 8MM	1/4	8mm	1.52	49.6	1.21	30.85
131PO _ 3/8 X 8 MM	3/8	8mm	2.0	50.9	1.15	29.2
131PO _ 3/8 X 12MM	3/8	12mm	2.24	56.9	1.39	35.2
131PO _ 1/2 X 12MM	1/2	12mm	2.47	62.74	1.45	36.48
131PO _ 3/4 X 18MM	3/4	18mm	3.14	79.8	1.50	38.05

Ordering Information	Hose I.D.	B Tube O.D.	E		M	
			inch	mm	inch	mm
<b>POP INCH</b>						
131POP _ 1/4 X 1/4	1/4	1/4	1.89	48.0	1.17	29.65
131POP _ 1/4 X 3/16	1/4	3/16	1.63	41.5	0.91	23.15

**NOTE:** For other end connection styles and sizes please contact your local Ham-Let representative.





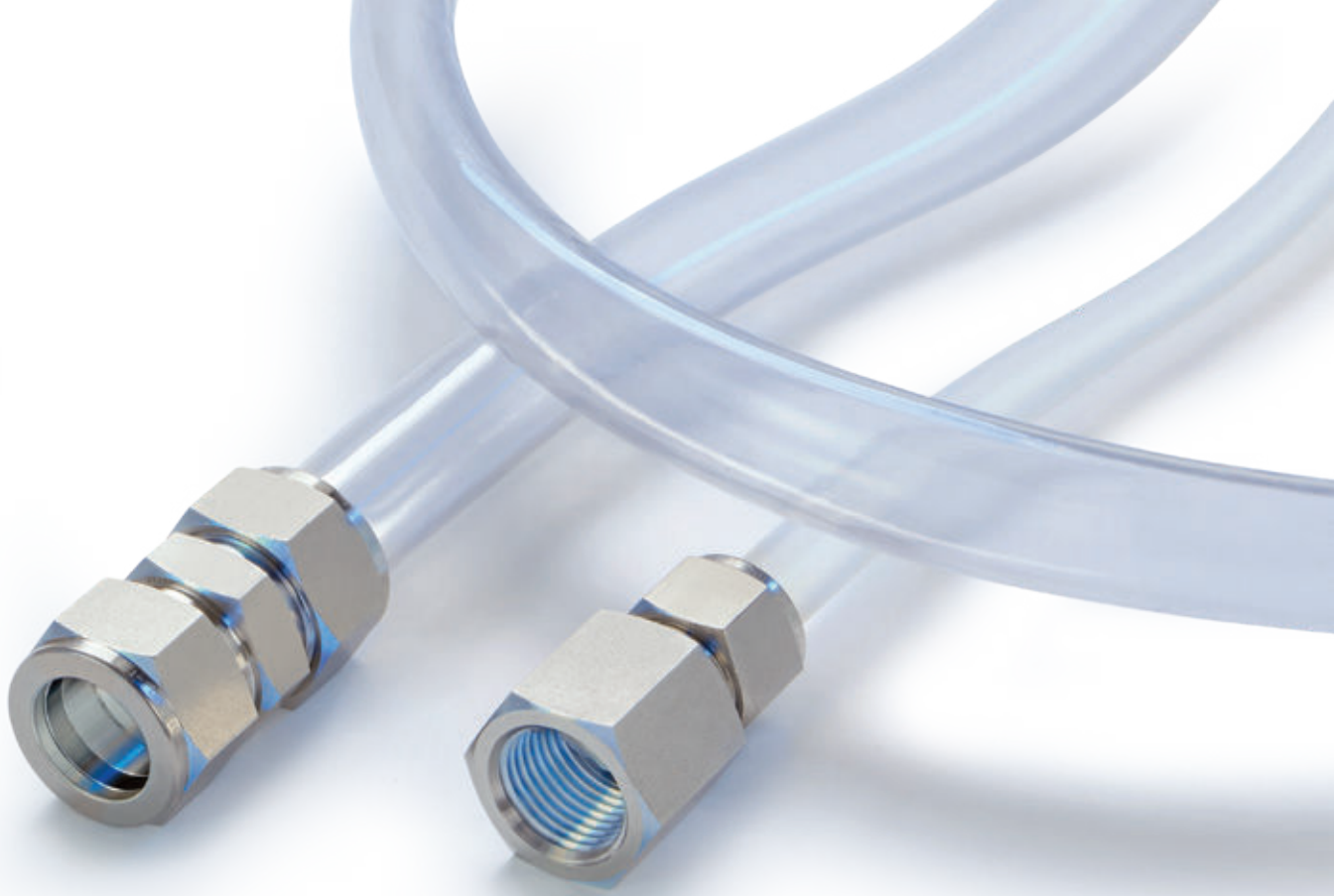

# **HAM-LET PFA HOSES**

## COMPONENTS



# Bulk PFA Hoses

Available for ordering as:

- cut length up to 100 feet (30.5 meter)
- Reel of fix length 164 feet (50 meter) for all sizes

## HOW TO ORDER

P		H		G		04		30		50M	
Line		Hoses		Series		Tube OD		Wall Thickness		Bulk Hoses	
P	PFA	H	Hose	G	General use	04	1/4	30	0.030"	50M	50 meters
						06	3/8	47	0.047"		
						08	1/2	62	0.062"		
						12	3/4	77	0.070"		
						16	1	0.75M	0.75mm		
						32	2	1M	1.00mm		
						4M	4mm	1.2M	1.20mm		
						6M	6mm	1.6M	1.60mm		
						8M	8mm				
						10M	10mm				
						12M	12mm				
						14M	14mm				

### Warning!

The system designer and user have the sole responsibility for selecting products suitable for their special application requirements, ensuring their safe and trouble-free installation, operation, and maintenance. Application details, material compatibility and product ratings should all be considered for each selected product. Improper selection, installation or use of products can cause property damage or personal injury.

## HAM-LET PFA HOSES COMPONENTS

### PHG Series - PFA tube, Imperial sizes

Outside Diameter		Nominal wall Thickness	Maximum Working Pressure		Dynamic Minimum Bend Radius		Inside Diameter		Burst Pressure		Weight Per Foot	Weight Per Meter
inch	mm	inch	psi	bar	inch	mm	inch	mm	psi	bar	lbs	kg
1/8	3.18	0.030	351	24.2	0.3	7	1/16	1.58	1,404	96.8	0.009	0.013
1/4	6.35	0.047	223	15.4	0.9	22	0.16	3.96	893	61.6	0.028	0.042
1/4	6.35	0.062	319	22.0	0.6	14	1/8	3.18	1,276	88.0	0.034	0.051
3/8	9.53	0.062	186	12.8	1.6	40	1/4	6.35	743	51.2	0.057	0.085
1/2	12.70	0.062	144	9.9	3.1	79	3/8	9.53	574	39.6	0.08	0.119
3/4	19.05	0.062	94	6.5	7.6	194	5/8	15.88	377	26.0	0.125	0.186
1	25.40	0.062	64	4.4	14.2	360	7/8	22.22	255	17.6	0.171	0.254
1 1/4	31.75	0.077	62	4.3	18.0	457	1.10	27.9	249	17.2	0.264	0.393

### PHG Series - PFA tube, Metric sizes

Outside Diameter		Nominal wall Thickness	Maximum Working Pressure		Dynamic Minimum Bend Radius		Inside Diameter		Burst Pressure		Weight Per Foot	Weight Per Meter
inch	mm	mm	psi	bar	inch	mm	inch	mm	psi	bar	lbs	kg
0.16	4	1.00	319	22.0	0.35	9	0.08	2.0	1,276	88.0	0.013	0.020
0.16	4	0.75	232	16.0	0.55	14	0.10	2.5	928	64.0	0.011	0.016
0.24	6	1.20	248	17.1	0.75	19	0.14	3.6	992	68.4	0.026	0.039
0.24	6	1.00	191	13.2	0.98	25	0.16	4.0	766	52.8	0.023	0.034
0.31	8	1.20	175	12.1	1.54	39	0.22	5.6	702	48.4	0.037	0.055
0.31	8	1.00	139	9.6	1.93	49	0.24	6.0	557	38.4	0.032	0.047
0.39	10	1.60	175	12.1	1.73	44	0.27	6.08	702	48.4	0.061	0.091
0.39	10	1.00	112	7.7	3.19	81	0.31	8.0	447	30.8	0.041	0.061
0.47	12	1.60	144	9.9	2.68	68	0.35	8.8	574	39.6	0.074	0.110
0.47	12	1.00	88	6.1	4.76	121	0.39	10.0	354	24.4	0.050	0.074
0.55	14	1.00	75	5.2	6.65	169	0.47	12.0	302	20.8	0.059	0.088

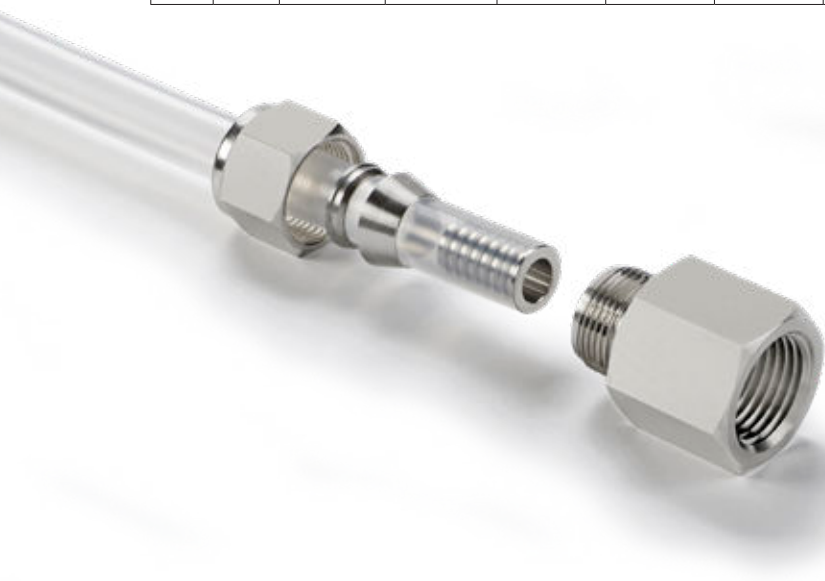

## HAM-LET PFA HOSES COMPONENTS | FITTINGS

### TUBE INSERT

760 LI

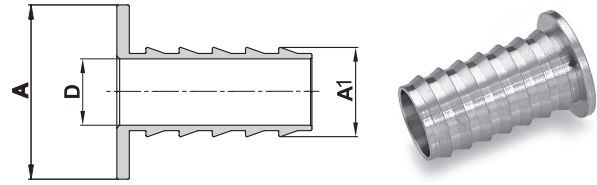

Ordering information (METRIC)	A Tube O.D		D
	mm	mm	
760LI _ 6 X 4	6	4	2.8
760LI _ 8 X 6	8	6	4.4
760LI _ 10 X 8	10	8	6.4
760LI _ 12 X 8	12	8	6.4
760LI _ 12 X 10	12	10	8.3

Ordering information (INCH)	A Tube O.D		A1 Tube O.D		D	
	inch	mm	inch	mm	inch	mm
760LI _ 3/16 X 1/8	3/16	4.76	1/8	3.17	0.09	2.30
760LI _ 1/4 X 1/8	1/4	6.35	1/8	3.17	0.09	2.30
760LI _ 1/4 X 0.17	1/4	6.35	.17	4.32	0.11	2.70
760LI _ 1/4 X 3/16	1/4	6.35	3/16	4.76	0.12	3.10
760LI _ 5/16 X 1/8	5/16	7.93	1/8	3.17	0.09	2.30
760LI _ 5/16 X 3/16	5/16	7.93	3/16	4.76	0.12	3.00
760LI _ 5/16 X 1/4	5/16	7.93	1/4	6.35	0.18	4.65
760LI _ 3/8 X 3/16	3/8	9.52	3/16	4.76	0.12	3.10
760LI _ 3/8 X 1/4	3/8	9.52	1/4	6.35	0.18	4.65
760LI _ 1/2 X 1/4	1/2	12.70	1/4	6.35	0.18	4.65
760LI _ 1/2 X 3/8	1/2	12.70	3/8	9.52	0.31	7.80
760LI _ 5/8 X 3/8	5/8	15.87	3/8	9.52	0.31	7.80
760LI _ 5/8 X 1/2	5/8	15.87	1/2	12.70	0.44	11.10
760LI _ 3/4 X 1/2	3/4	19.05	1/2	12.70	0.44	11.10
760LI _ 3/4 X 5/8	3/4	19.05	5/8	15.87	0.56	14.20
760LI _ 1 X 3/4	1	25.40	3/4	19.05	0.69	17.50

All Let-lok ferrules and nuts are compatible.



# HAM-LET EXPANSION JOINTS



# HAM-LET EXPANSION JOINTS

## General

Ham-Let offers a complete range of Pre-Engineered and Custom Designed high quality all Stainless Steel expansion joint. Expansion joints in 2" and higher diameters completes Ham-Let offering of hoses size ¼" to 2" as the solution for flexible section in tube and pipe systems.

## Features

Nominal diameter 2" and above  
Working pressures range Vacuum up to 1,000psi (69bar)  
Working temperatures -450 F° (-268 C°)  
up to 1,500 F° (815 C°)  
Wide range of stainless steel and nickel alloys  
construction materials available

## Comprehensive Product Range

### Pre-engineered expansion joint products

Pre-engineered expansion joint products incorporate designs for common industrial applications to provide more immediate order availability. For pre-engineered expansion joint please refer to pages 6 for product designs and specifications.

### Custom Designed Expansion Joints

As no two systems are identical, off-the-shelf solutions are often impractical for addressing all critical variables of the most demanding applications. Custom designed expansion joint products start at 2" nominal diameter, and are available with an array of alloys and end fittings to suit any expansion joint application. Because of their many options, custom designed expansion joints are engineered to suit specific needs. Please refer to pages 4-5 for product offerings and our Expansion Joint Specification Inquiry Sheet on pages 12-13.

## Pressure Thrust Balancing

### Pressure-balanced expansion joints

Pressure-balanced expansion joints balance the pressure thrust within the expansion joint assembly through the addition of an opposing (or balancing) bellows. This greatly simplifies piping anchor and support requirements. Turbines and other reciprocating equipment frequently require the implementation of pressure-balanced expansion joints to eliminate nozzle loads due to pressure thrust.

Most common pressure-balanced systems require a change in piping direction. These applications use our Pressure-Balanced Single (PBS) or Pressure-Balanced Universal (PBU) styles. For those applications where there is no change in piping direction our Pressure-Balanced In-Line (PBI) style is the preferred selection. Please refer to page 4-5 for details.

## Design Assistance Package

Product quotation includes a design package complete with full performance specifications and detailed engineering drawings.

**Cover Sheet** - Lists standard manufacturing procedures and provides summary of options selected in accordance with the expansion joint design, including:

- Test and inspection criteria
- Tagging and identification specifications
- Accessories (such as lifting lugs and insulation)
- Certifications (such as agency approval, material origin, conformance, and fabrication)
- Finishing details
- Packaging and shipping accessories

**Design Stress Analysis** - Documents the bellows design specifications and corresponding forces acting upon the piping system in which the expansion joint will be installed.

- Expansion Joint Design Parameters (Pressure, Temperature, Design Cycle Life, Movements)
- Bellows Performance Data (Cycle Life, Operating Pressure)
- Bellows Spring Forces (Spring Rates and Resultant Force)
- Pressure Thrust (Area, Pressure, and Resultant Force)
- Individual stresses for the given bellows convolution profile
- Detailed Drawings and Components List
- Drawings completed to scale, with maximum envelope dimensions
- Component list showing all materials used in manufacturing

## Expansion Joints Vs. Metal Hose

Braided metal hose assemblies and expansion joints share many similar attributes, but it is their differences in construction that determine which is best for a specific application. Braided metal hose assemblies are constructed from flexible, corrugated hose typically formed using a single layer of strip.

The number of corrugations per foot dictates the flexibility of the hose, while the outer braid layer provides its pressure bearing capability. Braided metal hoses are designed to accommodate two types of movement: either lateral (side to side), or angular (one end moving, or bending, relative to the other).

Axial movement (compression or extension) is to be avoided, as it can cause the braid to loosen from the hose, thus reducing its pressure bearing capability and leaving the hose susceptible to squirm. Because expansion joints are designed to accommodate pressure and movements without the need for braid, they are capable of handling all three types of movement: lateral, angular, and axial. Expansion joint movement and pressure bearing capabilities are determined by the number of convolutions, as well as material thickness, number of plies, and wall

height specified by the product's individual design. Multi-ply expansion joints are ideally suited for applications where vibration may be present. Additionally, multi-ply designs feature lower spring rates which reduces stress on piping components, and increases cycle life for a given installation.









# Expansion Joint Range

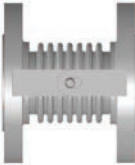

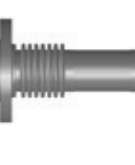

Size Range:	Alloys:	Pressure	Temperature
From 2" - 120" nominal diameter (tube sizes also available)  Single and multi-ply	Stainless steels - T304, T304L, T309, T310, T321, T316, T316L Nickel - 400, 600, 625, 625LCF, 800, 800H, Nickel 200, C276 Other alloys available upon request	From full vacuum to 1,000 psi (69bar)	Range from -450°F to 1,500° F (-268°C to 815°C)

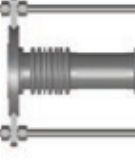
## Regular

	<b>US</b> Unrestrained Single		<b>SHS</b> Slotted Hinged Single
	<b>LS</b> Limit Single		<b>GS</b> Gimballed Single
	<b>TS</b> Tied Single		<b>UU</b> Unrestrained Universal
	<b>HS</b> Hinged Single		<b>TU</b> Tied Universal

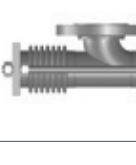
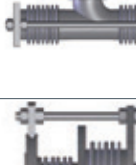
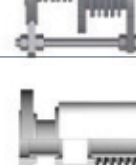
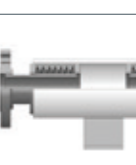
## Pressure-Balanced

	<b>PBS</b> Pressure Balanced, Elbow, Single
	<b>PBU</b> Pressure Balanced, Elbow, Universal
	<b>PBI</b> Pressure Balanced In-Line
	<b>EPS</b> Externally Pressurized Single
	<b>EPD</b> Externally Pressurized Dual

## INTERNAL LINERS

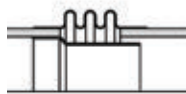

**SW - Single Welded**  
These liners are the most common type of internal liner.



**TW - Telescoping Welded**  
These liners are used when large axial movement is a concern.

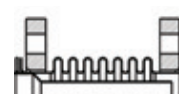

**SD - Single Drop-in**  
These liners can be removed for cleaning.

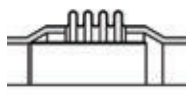

**FW - Flush Welded**  
Also known as "full-flow liners", these offer no protrusion into flow stream and cause minimal pressure drop.

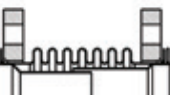

**TD - Telescoping Drop-in**  
These liners are used for large axial movement and can be removed and cleaned.

# Comparison Of Ratings, Features & Options

Expansion Joint Types	Relative Movement Capacity			Relative Spring Forces			Pressure Thrust on a Piping System	Available Features		
	Axial	Angular	Lateral	Axial	Angular	Lateral		Internal Flow Liner Types	External Cover	Redundant Ply Design
<b>US</b> Unrestrained Single	M	M	L	M	M	H	Yes	SW,TW, FW, SD, TD	Yes	Yes
<b>LS</b> Limit Single	M	M	L	M	M	H	Yes	SW,TW, FW, SD, TD	Yes	Yes
<b>TS</b> Tied Single	-	-	L	-	-	H	No	SW,TW, FW, SD, TD	Yes	Yes
<b>HS</b> Hinged Single	-	M	-	-	M	-	No	SW,TW, FW, SD, TD	Yes	Yes
<b>SHS</b> Slotted Hinge Single	M	M	-	M	M	-	Yes	SW,TW, FW, SD, TD	Yes	Yes
<b>GS</b> Gimbaled Single	-	M	-	-	M	-	No	SW,TW, FW, SD, TD	Yes	Yes
<b>UU</b> Unrestrained Universal	M	M	H	M	M	L	Yes	SW,TW, FW, SD, TD	Yes	Yes
<b>TU</b> Tied Universal	-	-	H	-	-	L	No	SW,TW, FW, SD, TD	Yes	Yes
<b>PBS</b> Pressure-Balanced, Elbow, Single	M	-	M	M	M	H	No	SW,TW, FW, SD, TD	Yes	Yes
<b>PBU</b> Pressure-Balanced, Elbow, Universal	M	-	H	M	M	L	No	SW,TW, FW, SD, TD	Yes	Yes
<b>PBI</b> Pressure-Balanced, In-Line	M	-	-	M	-	-	No	SW,TW, FW, SD, TD	Yes	Yes
<b>EPS</b> Externally-Pressurized Single	H	-	-	M	-	-	Yes	FW	incl	Yes
<b>EPD</b> Externally-Pressurized Dual	H	-	-	M	-	-	Yes	FW	incl	Yes

H- High    M- Medium    L- Low

## Options

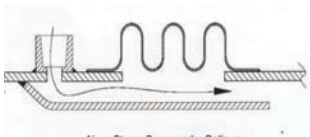

Purge Ports



Packed Bellows



Self-Draining Liner

# Pre-Engineered Expansion Joint Types

There are four basic designs that are most commonly used. Each is available in 15, 50, 150, and 300 psi (1, 3.5, 10, 20 bar) design pressures and is manufactured from T321 or T316 stainless steel. Available sizes range from 2" - 30" nominal diameter.



## BASIC BELLOWS

A bellows can be supplied without end fittings for field installation. The skirt (straight portion at each end of the bellows) can be sized to fit a flange or pipe. Please specify skirt length and attachment type when ordering.

## UNRESTRAINED SINGLE

An unrestrained single expansion joint is best used when piping systems are equipped with proper guides and anchors to absorb axial, angular, and a small amount of lateral movement.

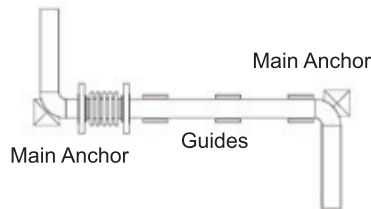
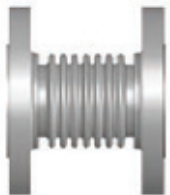

Example of an unrestrained single expansion joint used in a proper piping system to absorb axial pipeline expansion.

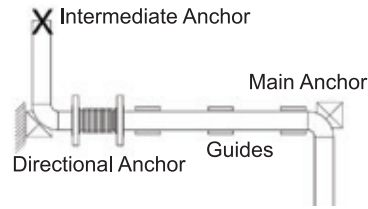

Example of an unrestrained single expansion joint used in a proper piping system to absorb lateral deflection as well as axial compression.

## LIMIT SINGLE

A limit single expansion joint is best used when main anchors and guides are in the pipeline. It allows for some axial movement as well as lateral movement; however, the hardware protects the expansion joint from exceeding its design movements.

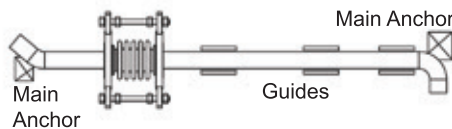
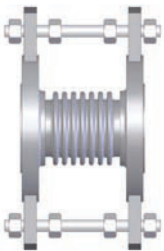

Example of a Limit Single expansion joint used in piping systems with main anchors. The limit rods prevent damage to the expansion joint and piping system by absorbing full pressure thrust.

## TIED SINGLE

A tied single expansion joint is best used in piping systems without a main anchor. It allows for lateral movement only while also restraining pressure thrust.

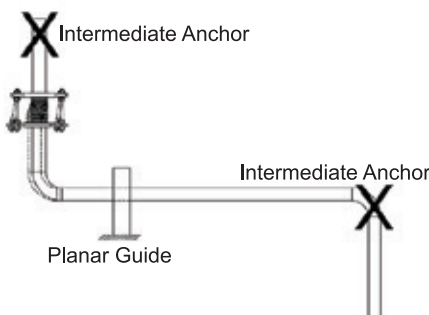
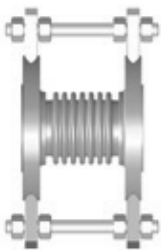

Example of a Tied Single expansion joint where the expansion joint is installed 90° to the thermal growth of the piping. Because of the rods, the expansion joint is able to absorb lateral movement only.

# 15PSI Pre-Engineered Expansion Joints Products

Specifications for 800°F (427°C)

Pipe Size	No. of Conv.	Live Length	Axial Movement	Lateral Movement	Axial Spring Rate	Lateral Spring Rate	Angular Spring Rate	Bellows Weight	150# Fixed or Floating Light Weight Plate Flanges		Weld Nipples	
									OAL	Weight	OAL	Weight
Inch (mm)	#	Inch (mm)	Inch (mm)	Inch (mm)	lbs/Inch (N/mm)	lbs/Inch (N/mm)	lbs-Inch/deg (N-mm/deg)	lbs (Kg)	Inch (mm)	lbs (Kg)	Inch (mm)	lbs (Kg)
2	3	1.125 (29)	0.188 (5)	0.031 (1)	1033 (181)	8414 (1474)	16 (3)	0.30 (0.14)	2.50 (64)	8 (4)	4.13 (105)	1 (0.45)
	5	1.875 (48)	0.375 (10)	0.090 (2)	620 (109)	1817 (318)	9 (2)	0.30 (0.14)	3.25 (83)	9 (4)	4.88 (124)	1 (0.45)
	7	2.500 (64)	0.500 (13)	0.125 (3)	419 (73)	692 (121)	6 (1)	0.40 (0.18)	3.88 (99)	9 (4)	5.50 (140)	1 (0.45)
	9	3.250 (83)	0.688 (17)	0.250 (6)	330 (58)	322 (56)	5 (1)	0.50 (0.23)	4.63 (118)	9 (4)	6.25 (159)	1 (0.45)
	11	4.000 (102)	0.813 (21)	0.438 (11)	272 (48)	175 (31)	4 (1)	0.50 (0.23)	5.38 (137)	9 (4)	7.00 (178)	1 (0.45)
	13	4.750 (121)	1.000 (25)	0.563 (14)	231 (40)	106 (19)	3 (1)	0.60 (0.27)	6.13 (156)	9 (4)	7.75 (197)	2 (0.91)
	15	5.500 (140)	1.125 (29)	0.813 (21)	201 (35)	69 (12)	3 (1)	0.70 (0.32)	6.88 (175)	9 (4)	8.50 (216)	2 (0.91)
2.5	3	1.250 (32)	0.313 (8)	0.031 (1)	812 (142)	8525 (1493)	19 (3)	0.40 (0.18)	2.63 (67)	11 (5)	4.25 (108)	2 (0.91)
	5	2.000 (51)	0.500 (13)	0.063 (2)	467 (82)	1914 (335)	11 (2)	0.50 (0.23)	3.38 (86)	11 (5)	5.00 (127)	2 (0.91)
	7	2.875 (73)	0.688 (17)	0.188 (5)	342 (60)	680 (119)	8 (1)	0.60 (0.27)	4.25 (108)	11 (5)	5.88 (149)	2 (0.91)
	9	3.625 (92)	0.938 (24)	0.313 (8)	261 (46)	326 (57)	6 (1)	0.70 (0.32)	5.00 (127)	11 (5)	6.63 (168)	2 (0.91)
	11	4.500 (114)	1.125 (29)	0.500 (13)	217 (38)	176 (31)	5 (1)	0.80 (0.36)	5.88 (149)	12 (5)	7.50 (191)	2 (0.91)
	13	5.250 (133)	1.313 (33)	0.688 (17)	181 (32)	108 (19)	4 (1)	0.90 (0.41)	6.63 (168)	12 (5)	8.25 (210)	2 (0.91)
3	3	1.375 (35)	0.438 (11)	0.031 (1)	435 (76)	5352 (937)	15 (3)	0.50 (0.23)	2.75 (70)	12 (5)	4.63 (118)	3 (1.36)
	5	2.250 (57)	0.750 (19)	0.125 (3)	256 (45)	1176 (206)	9 (2)	0.60 (0.27)	3.63 (92)	12 (5)	5.50 (140)	3 (1.36)
	7	3.125 (79)	1.125 (29)	0.250 (6)	181 (32)	432 (76)	6 (1)	0.80 (0.36)	4.50 (114)	13 (6)	6.38 (162)	3 (1.36)
	9	4.000 (102)	1.438 (37)	0.438 (11)	140 (25)	204 (36)	5 (1)	0.90 (0.41)	5.38 (137)	13 (6)	7.25 (184)	3 (1.36)
	11	4.875 (124)	1.750 (44)	0.688 (17)	115 (20)	112 (20)	4 (1)	1.10 (0.5)	6.25 (159)	13 (6)	8.13 (207)	3 (1.36)
	13	5.750 (146)	2.063 (52)	1.000 (25)	97 (17)	68 (12)	3 (1)	1.20 (0.54)	7.13 (181)	13 (6)	9.00 (229)	3 (1.36)
	15	6.625 (168)	2.438 (62)	1.313 (33)	84 (15)	44 (8)	3 (1)	1.40 (0.64)	8.00 (203)	13 (6)	9.88 (251)	3 (1.36)
4	3	1.500 (38)	0.500 (13)	0.031 (1)	537 (94)	8534 (1495)	28 (5)	0.60 (0.27)	2.88 (73)	17 (8)	4.63 (118)	3 (1.36)
	5	2.375 (60)	0.813 (21)	0.125 (3)	307 (54)	1944 (340)	16 (3)	0.80 (0.36)	3.75 (95)	17 (8)	5.50 (140)	4 (1.81)
	7	3.375 (86)	1.188 (30)	0.250 (6)	222 (39)	697 (122)	12 (2)	1.00 (0.45)	4.75 (121)	17 (8)	6.50 (165)	4 (1.81)
	9	4.375 (111)	1.500 (38)	0.438 (11)	174 (30)	325 (57)	9 (2)	1.20 (0.54)	5.75 (146)	17 (8)	7.50 (191)	4 (1.81)
	11	5.375 (137)	1.875 (48)	0.688 (17)	143 (25)	177 (31)	7 (1)	1.40 (0.64)	6.75 (171)	18 (8)	8.50 (216)	4 (1.81)
	13	6.250 (159)	2.188 (56)	0.938 (24)	119 (21)	109 (19)	6 (1)	1.60 (0.73)	7.63 (194)	18 (8)	9.38 (238)	4 (1.81)
	15	7.250 (184)	2.563 (65)	1.250 (32)	104 (18)	71 (12)	5 (1)	1.80 (0.82)	8.63 (219)	18 (8)	10.38 (264)	5 (2.27)
5	3	1.625 (41)	0.688 (17)	0.063 (2)	350 (61)	7560 (1324)	29 (5)	0.90 (0.41)	2.75 (70)	15 (7)	6.38 (162)	7 (3.18)
	5	2.750 (70)	1.188 (30)	0.125 (3)	213 (37)	1606 (281)	18 (3)	1.20 (0.54)	3.88 (99)	16 (7)	7.50 (191)	7 (3.18)
	7	3.875 (98)	1.688 (43)	0.313 (8)	153 (27)	581 (102)	13 (2)	1.50 (0.68)	5.00 (127)	16 (7)	8.63 (219)	7 (3.18)
	9	5.000 (127)	2.188 (56)	0.563 (14)	120 (21)	272 (48)	10 (2)	1.80 (0.82)	6.13 (156)	16 (7)	9.75 (248)	8 (3.63)
	11	6.125 (156)	2.688 (68)	0.875 (22)	98 (17)	149 (26)	8 (1)	2.10 (0.95)	7.25 (184)	16 (7)	10.88 (276)	8 (3.63)
	13	7.375 (187)	2.750 (70)	1.063 (27)	136 (24)	142 (25)	11 (2)	2.80 (1.27)	8.50 (216)	17 (8)	12.13 (308)	9 (4.08)
	15	8.500 (216)	3.188 (81)	1.438 (37)	118 (21)	93 (16)	10 (2)	3.20 (1.45)	9.63 (245)	18 (8)	13.25 (337)	9 (4.08)
6	3	1.625 (41)	0.750 (19)	0.031 (1)	396 (69)	11730 (2055)	45 (8)	1.10 (0.5)	2.75 (70)	18 (8)	6.25 (159)	8 (3.63)
	5	2.750 (70)	1.250 (32)	0.125 (3)	239 (42)	2473 (433)	27 (5)	1.50 (0.68)	3.88 (99)	18 (8)	7.38 (187)	8 (3.63)
	7	3.875 (98)	1.750 (44)	0.313 (8)	171 (30)	892 (156)	20 (4)	1.90 (0.86)	5.00 (127)	19 (9)	8.50 (216)	9 (4.08)
	9	5.000 (127)	2.250 (57)	0.500 (13)	133 (23)	418 (73)	15 (3)	2.20 (1)	6.13 (156)	19 (9)	9.63 (245)	9 (4.08)
	11	6.125 (156)	2.750 (70)	0.750 (19)	109 (19)	228 (40)	12 (2)	2.60 (1.18)	7.25 (184)	19 (9)	10.75 (273)	9 (4.08)
	13	7.250 (184)	3.000 (76)	0.938 (24)	92 (16)	138 (24)	11 (2)	2.90 (1.32)	8.38 (213)	20 (9)	11.88 (302)	10 (4.54)
	15	8.500 (216)	3.188 (81)	1.250 (32)	134 (23)	145 (25)	15 (3)	3.90 (1.77)	9.63 (245)	21 (10)	13.13 (334)	11 (4.99)

# 50PSI Pre-Engineered Expansion Joints Products

Specifications for 800°F (427°C)

Pipe Size	No. of Conv.	Live Length	Axial Movement	Lateral Movement	Axial Spring Rate	Lateral Spring Rate	Angular Spring Rate	Bellows Weight	150# Fixed or Floating Light Weight Plate Flanges		Weld Nipples	
									OAL	Weight	OAL	Weight
Inch (mm)	#	Inch (mm)	Inch (mm)	Inch (mm)	lbs/Inch (N/mm)	lbs/Inch (N/mm)	lbs-Inch/deg (N-mm/deg)	lbs (Kg)	Inch (mm)	lbs (Kg)	Inch (mm)	lbs (Kg)
2	3	1.000 (25)	0.219 (6)	0.031 (1)	719 (126)	7394 (1295)	11 (2)	0.16 (0.07)	2.38 (60)	8 (4)	4.00 (102)	1 (0.45)
	5	1.750 (44)	0.375 (10)	0.063 (2)	440 (77)	1476 (259)	7 (1)	0.20 (0.09)	3.13 (80)	8 (4)	4.75 (121)	1 (0.45)
	7	2.500 (64)	0.563 (14)	0.188 (5)	317 (56)	522 (91)	5 (1)	0.24 (0.11)	3.88 (99)	8 (4)	5.50 (140)	1 (0.45)
	9	3.125 (79)	0.750 (19)	0.250 (6)	243 (43)	256 (45)	4 (1)	0.28 (0.13)	4.50 (114)	8 (4)	6.13 (156)	1 (0.45)
	11	3.875 (98)	0.938 (24)	0.438 (11)	195 (34)	134 (23)	3 (1)	0.32 (0.15)	5.25 (133)	9 (4)	6.88 (175)	1 (0.45)
	13	4.625 (117)	1.063 (27)	0.625 (16)	206 (36)	101 (18)	3 (1)	0.44 (0.2)	6.00 (152)	9 (4)	7.63 (194)	1 (0.45)
2.5	15	5.375 (137)	1.063 (27)	0.688 (17)	260 (46)	94 (16)	4 (1)	0.56 (0.25)	6.75 (171)	9 (4)	8.38 (213)	1 (0.45)
	3	1.125 (29)	0.313 (8)	0.031 (1)	567 (99)	7349 (1287)	14 (2)	0.22 (0.1)	2.50 (64)	11 (5)	4.13 (105)	2 (0.91)
	5	2.000 (51)	0.563 (14)	0.063 (2)	349 (61)	1430 (250)	8 (1)	0.28 (0.13)	3.38 (86)	11 (5)	5.00 (127)	2 (0.91)
	7	2.750 (70)	0.750 (19)	0.188 (5)	247 (43)	536 (94)	6 (1)	0.34 (0.15)	4.13 (105)	11 (5)	5.75 (146)	2 (0.91)
	9	3.500 (89)	1.000 (25)	0.313 (8)	191 (33)	256 (45)	5 (1)	0.40 (0.18)	4.88 (124)	11 (5)	6.50 (165)	2 (0.91)
	11	4.250 (108)	1.125 (29)	0.438 (11)	217 (38)	199 (35)	5 (1)	0.55 (0.25)	5.63 (143)	11 (5)	7.25 (184)	2 (0.91)
3	13	5.125 (130)	1.188 (30)	0.563 (14)	265 (46)	167 (29)	6 (1)	0.71 (0.32)	6.50 (165)	12 (5)	8.13 (207)	2 (0.91)
	15	6.000 (152)	1.375 (35)	0.813 (21)	228 (40)	105 (18)	6 (1)	0.79 (0.36)	7.38 (187)	12 (5)	9.00 (229)	2 (0.91)
	3	1.250 (32)	0.500 (13)	0.031 (1)	312 (55)	4648 (814)	11 (2)	0.28 (0.13)	2.63 (67)	12 (5)	4.50 (114)	2 (0.91)
	5	2.125 (54)	0.813 (21)	0.125 (3)	189 (33)	971 (170)	6 (1)	0.37 (0.17)	3.50 (89)	12 (5)	5.38 (137)	2 (0.91)
	7	3.000 (76)	1.188 (30)	0.250 (6)	135 (24)	349 (61)	5 (1)	0.46 (0.21)	4.38 (111)	12 (5)	6.25 (159)	3 (1.36)
	9	3.875 (98)	1.313 (33)	0.438 (11)	162 (28)	251 (44)	5 (1)	0.65 (0.29)	5.25 (133)	13 (6)	7.13 (181)	3 (1.36)
4	11	4.750 (121)	1.438 (37)	0.563 (14)	193 (34)	199 (35)	7 (1)	0.86 (0.39)	6.13 (156)	13 (6)	8.00 (203)	3 (1.36)
	13	5.750 (146)	1.563 (40)	0.750 (19)	230 (40)	162 (28)	8 (1)	1.10 (0.5)	7.13 (181)	13 (6)	9.00 (229)	3 (1.36)
	15	6.625 (168)	1.625 (41)	0.875 (22)	255 (45)	136 (24)	9 (2)	1.39 (0.63)	8.00 (203)	13 (6)	9.88 (251)	3 (1.36)
	3	1.375 (35)	0.500 (13)	0.031 (1)	390 (68)	7378 (1292)	20 (4)	0.36 (0.16)	2.75 (70)	16 (7)	4.50 (114)	3 (1.36)
	5	2.375 (60)	0.875 (22)	0.125 (3)	237 (42)	1503 (263)	12 (2)	0.48 (0.22)	3.75 (95)	16 (7)	5.50 (140)	3 (1.36)
	7	3.250 (83)	1.188 (30)	0.250 (6)	168 (29)	568 (99)	9 (2)	0.60 (0.27)	4.63 (118)	17 (8)	6.38 (162)	3 (1.36)
5	9	4.250 (108)	1.375 (35)	0.375 (10)	201 (35)	399 (70)	10 (2)	0.83 (0.38)	5.63 (143)	17 (8)	7.38 (187)	4 (1.81)
	11	5.250 (133)	1.500 (38)	0.500 (13)	240 (42)	312 (55)	13 (2)	1.11 (0.5)	6.63 (168)	17 (8)	8.38 (213)	4 (1.81)
	13	6.250 (159)	1.625 (41)	0.688 (17)	274 (48)	251 (44)	14 (2)	1.44 (0.65)	7.63 (194)	17 (8)	9.38 (238)	4 (1.81)
	15	7.250 (184)	1.750 (44)	0.813 (21)	297 (52)	204 (36)	16 (3)	1.83 (0.83)	8.63 (219)	18 (8)	10.38 (264)	5 (2.27)
	3	1.625 (41)	0.750 (19)	0.063 (2)	273 (48)	5890 (1032)	23 (4)	0.51 (0.23)	3.25 (83)	21 (10)	6.38 (162)	6 (2.72)
	5	2.750 (70)	1.250 (32)	0.188 (5)	162 (28)	1221 (214)	13 (2)	0.70 (0.32)	4.38 (111)	21 (10)	7.50 (191)	6 (2.72)
6	7	3.875 (98)	1.563 (40)	0.313 (8)	177 (31)	673 (118)	15 (3)	1.02 (0.46)	5.50 (140)	21 (10)	8.63 (219)	7 (3.18)
	9	5.000 (127)	1.563 (40)	0.438 (11)	265 (46)	608 (106)	22 (4)	1.61 (0.73)	6.63 (168)	22 (10)	9.75 (248)	7 (3.18)
	11	6.125 (156)	1.813 (46)	0.563 (14)	289 (51)	442 (77)	24 (4)	2.10 (0.95)	7.75 (197)	22 (10)	10.88 (276)	8 (3.63)
	13	7.375 (187)	1.813 (46)	0.688 (17)	423 (74)	458 (80)	36 (6)	3.07 (1.39)	9.00 (229)	23 (10)	12.13 (308)	9 (4.08)
	15	8.625 (219)	2.000 (51)	0.938 (24)	398 (70)	307 (54)	33 (6)	3.42 (1.55)	10.25 (260)	23 (10)	13.38 (340)	9 (4.08)
	3	1.625 (41)	0.750 (19)	0.031 (1)	313 (55)	9272 (1624)	36 (6)	0.68 (0.31)	3.25 (83)	23 (10)	6.25 (159)	8 (3.63)
7	5	2.750 (70)	1.250 (32)	0.125 (3)	188 (33)	1950 (342)	22 (4)	0.90 (0.41)	4.38 (111)	23 (10)	7.38 (187)	8 (3.63)
	7	3.875 (98)	1.563 (40)	0.250 (6)	207 (36)	1080 (189)	24 (4)	1.30 (0.59)	5.50 (140)	23 (10)	8.50 (216)	8 (3.63)
	9	5.000 (127)	1.750 (44)	0.375 (10)	236 (41)	739 (129)	27 (5)	1.77 (0.8)	6.63 (168)	24 (11)	9.63 (245)	9 (4.08)
	11	6.125 (156)	1.875 (48)	0.500 (13)	271 (47)	566 (99)	31 (5)	2.32 (1.05)	7.75 (197)	24 (11)	10.75 (273)	9 (4.08)
	13	7.250 (184)	2.000 (51)	0.625 (16)	312 (55)	465 (81)	36 (6)	2.93 (1.33)	8.88 (226)	25 (11)	11.88 (302)	10 (4.54)
	15	8.625 (219)	2.063 (52)	0.813 (21)	431 (75)	459 (80)	50 (9)	4.30 (1.95)	10.25 (260)	26 (12)	13.25 (337)	11 (4.99)

# 150PS | Pre-Engineered Expansion Joints Products

Specifications for 800°F (427°C)

Pipe Size	No. of Conv.	Live Length	Axial Movement	Lateral Movement	Axial Spring Rate	Lateral Spring Rate	Angular Spring Rate	Bellows Weight	150# Fixed or Floating Light Weight Plate Flanges		Weld Nipples	
									OAL	Weight	OAL	Weight
Inch (mm)	#	Inch (mm)	Inch (mm)	Inch (mm)	lbs/Inch (N/mm)	lbs/Inch (N/mm)	lbs-Inch/deg (N-mm/deg)	lbs (Kg)	Inch (mm)	lbs (Kg)	Inch (mm)	lbs (Kg)
2	3	1.000 (25)	0.188 (5)	0.029 (1)	719 (126)	7394 (1295)	11 (2)	0.2 (0.09)	3.13 (80)	11 (5)	4.00 (102)	1 (0.45)
	5	1.750 (44)	0.375 (10)	0.063 (2)	440 (77)	1476 (259)	7 (1)	0.2 (0.09)	3.88 (99)	11 (5)	4.75 (121)	1 (0.45)
	6	2.000 (51)	0.313 (8)	0.063 (2)	995 (174)	2592 (454)	15 (3)	0.3 (0.14)	4.13 (105)	11 (5)	5.00 (127)	1 (0.45)
	7	2.500 (64)	0.500 (13)	0.125 (3)	317 (56)	522 (91)	5 (1)	0.2 (0.09)	4.63 (118)	11 (5)	5.50 (140)	1 (0.45)
	9	3.125 (79)	0.563 (14)	0.188 (5)	370 (65)	390 (68)	6 (1)	0.3 (0.14)	5.25 (133)	11 (5)	6.13 (156)	1 (0.45)
	11	4.000 (102)	0.625 (16)	0.313 (8)	432 (76)	278 (49)	6 (1)	0.4 (0.18)	6.13 (156)	11 (5)	7.00 (178)	1 (0.45)
	13	4.625 (117)	0.688 (17)	0.375 (10)	522 (91)	245 (43)	8 (1)	0.6 (0.27)	6.75 (171)	11 (5)	7.63 (194)	1 (0.45)
15	5.500 (140)	0.750 (19)	0.500 (13)	587 (103)	201 (35)	9 (2)	0.7 (0.32)	7.63 (194)	11 (5)	8.50 (216)	2 (0.91)	
2.5	3	1.125 (29)	0.250 (6)	0.031 (1)	787 (138)	10287 (1802)	19 (3)	0.3 (0.14)	3.50 (89)	16 (7)	4.13 (105)	3 (1.36)
	5	2.000 (51)	0.313 (8)	0.063 (2)	1078 (189)	4421 (774)	26 (5)	0.4 (0.18)	4.38 (111)	16 (7)	5.00 (127)	3 (1.36)
	7	2.750 (70)	0.625 (16)	0.125 (3)	341 (60)	747 (131)	8 (1)	0.4 (0.18)	5.13 (130)	16 (7)	5.75 (146)	3 (1.36)
	9	3.625 (92)	0.688 (17)	0.250 (6)	414 (73)	518 (91)	10 (2)	0.5 (0.23)	6.00 (152)	17 (8)	6.63 (168)	3 (1.36)
	11	4.625 (117)	0.750 (19)	0.313 (8)	490 (86)	420 (74)	12 (2)	0.7 (0.32)	7.00 (178)	17 (8)	7.63 (194)	3 (1.36)
	13	5.250 (133)	0.813 (21)	0.375 (10)	566 (99)	337 (59)	14 (2)	0.9 (0.41)	7.63 (194)	17 (8)	8.25 (210)	3 (1.36)
	15	6.500 (165)	1.063 (27)	0.688 (17)	813 (142)	316 (55)	19 (3)	1.7 (0.77)	8.88 (226)	18 (8)	9.50 (241)	4 (1.81)
3	3	1.375 (35)	0.313 (8)	0.031 (1)	1001 (175)	12307 (2156)	34 (6)	0.4 (0.18)	3.88 (99)	18 (8)	4.63 (118)	4 (1.81)
	4	1.750 (44)	0.438 (11)	0.031 (1)	818 (143)	6334 (1109)	28 (5)	0.6 (0.27)	4.25 (108)	19 (9)	5.00 (127)	4 (1.81)
	5	2.250 (57)	0.500 (13)	0.063 (2)	599 (105)	2749 (481)	20 (4)	0.6 (0.27)	4.75 (121)	19 (9)	5.50 (140)	4 (1.81)
	7	3.125 (79)	0.750 (19)	0.188 (5)	427 (75)	1017 (178)	14 (2)	0.7 (0.32)	5.63 (143)	19 (9)	6.38 (162)	4 (1.81)
	9	4.000 (102)	0.813 (21)	0.250 (6)	451 (79)	655 (115)	15 (3)	0.9 (0.41)	6.50 (165)	19 (9)	7.25 (184)	5 (2.27)
	10	4.625 (117)	0.913 (23)	0.080 (2)	436 (76)	497 (87)	15 (3)	1.0 (0.45)	7.13 (181)	19 (9)	7.88 (200)	5 (2.27)
	11	5.250 (133)	1.250 (32)	0.500 (13)	607 (106)	512 (90)	21 (4)	1.9 (0.86)	7.75 (197)	20 (9)	8.50 (216)	6 (2.72)
	13	6.250 (159)	1.313 (33)	0.688 (17)	718 (126)	426 (75)	24 (4)	2.4 (1.09)	8.75 (222)	20 (9)	9.50 (241)	6 (2.72)
15	7.500 (191)	1.500 (38)	0.938 (24)	839 (147)	343 (60)	28 (5)	2.6 (1.18)	10.00 (254)	21 (10)	10.75 (273)	6 (2.72)	
4	3	1.500 (38)	0.313 (8)	0.031 (1)	1239 (217)	19694 (3449)	65 (11)	0.6 (0.27)	4.25 (108)	26 (12)	4.63 (118)	6 (2.72)
	5	2.375 (60)	0.500 (13)	0.063 (2)	743 (130)	4709 (825)	39 (7)	0.7 (0.32)	5.13 (130)	26 (12)	5.50 (140)	6 (2.72)
	6	2.875 (73)	0.625 (16)	0.063 (2)	757 (133)	3301 (578)	40 (7)	0.9 (0.41)	5.63 (143)	26 (12)	6.00 (152)	6 (2.72)
	7	3.375 (86)	0.750 (19)	0.125 (3)	531 (93)	1667 (292)	28 (5)	0.9 (0.41)	6.13 (156)	26 (12)	6.50 (165)	6 (2.72)
	9	4.625 (117)	0.938 (24)	0.250 (6)	498 (87)	937 (164)	26 (5)	1.3 (0.59)	7.38 (187)	26 (12)	7.75 (197)	7 (3.18)
	11	5.625 (143)	1.250 (32)	0.500 (13)	710 (124)	804 (141)	37 (6)	2.5 (1.13)	8.38 (213)	28 (13)	8.75 (222)	8 (3.63)
	13	6.750 (171)	1.375 (35)	0.625 (16)	844 (148)	663 (116)	44 (8)	3.2 (1.45)	9.50 (241)	28 (13)	9.88 (251)	9 (4.08)
	15	8.250 (210)	1.500 (38)	0.875 (22)	913 (160)	480 (84)	48 (8)	4.7 (2.13)	11.00 (279)	30 (14)	11.38 (289)	10 (4.54)
5	3	1.750 (44)	0.313 (8)	0.031 (1)	2225 (390)	41387 (7249)	185 (32)	1.1 (0.5)	4.75 (121)	31 (14)	6.50 (165)	8 (3.63)
	5	2.750 (70)	0.688 (17)	0.063 (2)	713 (125)	5362 (939)	59 (10)	1.2 (0.54)	5.75 (146)	31 (14)	7.50 (191)	9 (4.08)
	7	4.000 (102)	0.813 (21)	0.125 (3)	953 (167)	3393 (594)	79 (14)	1.8 (0.82)	7.00 (178)	32 (15)	8.75 (222)	9 (4.08)
	8	4.375 (111)	1.000 (25)	0.188 (5)	740 (130)	1987 (348)	62 (11)	2.3 (1.04)	7.38 (187)	32 (15)	9.13 (232)	10 (4.54)
	9	5.125 (130)	1.063 (27)	0.250 (6)	741 (130)	1608 (282)	62 (11)	2.2 (1)	8.13 (207)	32 (15)	9.88 (251)	10 (4.54)
	11	6.875 (175)	1.375 (35)	0.500 (13)	1348 (236)	1624 (284)	112 (20)	5.1 (2.31)	9.88 (251)	35 (16)	11.63 (295)	13 (5.9)
	13	8.125 (206)	1.625 (41)	0.688 (17)	1140 (200)	984 (172)	95 (17)	5.9 (2.68)	11.13 (283)	36 (16)	12.88 (327)	13 (5.9)
	15	10.000 (254)	2.000 (51)	1.000 (25)	1466 (257)	841 (147)	123 (22)	10.1 (4.58)	13.00 (330)	40 (18)	14.75 (375)	17 (7.71)
6	3	1.750 (44)	0.313 (8)	0.028 (1)	2603 (456)	66529 (11653)	297 (52)	1.4 (0.64)	5.00 (127)	39 (18)	6.38 (162)	9 (4.08)
	5	2.875 (73)	0.563 (14)	0.063 (2)	1562 (274)	14790 (2590)	178 (31)	1.9 (0.86)	6.13 (156)	40 (18)	7.50 (191)	9 (4.08)
	7	4.000 (102)	0.813 (21)	0.125 (3)	1100 (193)	5389 (944)	126 (22)	2.3 (1.04)	7.25 (184)	40 (18)	8.63 (219)	10 (4.54)
	8	4.375 (111)	0.938 (24)	0.188 (5)	877 (154)	3231 (566)	101 (18)	2.6 (1.18)	7.63 (194)	41 (19)	9.00 (229)	10 (4.54)
	9	5.125 (130)	1.000 (25)	0.188 (5)	868 (152)	2586 (453)	99 (17)	2.8 (1.27)	8.38 (213)	41 (19)	9.75 (248)	10 (4.54)
	11	6.250 (159)	1.250 (32)	0.313 (8)	710 (124)	1423 (249)	81 (14)	3.2 (1.45)	9.50 (241)	41 (19)	10.88 (276)	11 (4.99)
	13	8.125 (206)	1.625 (41)	0.625 (16)	1207 (211)	1440 (252)	139 (24)	7.4 (3.36)	11.38 (289)	45 (20)	12.75 (324)	15 (6.8)
	15	9.375 (238)	1.875 (48)	0.813 (21)	1069 (187)	957 (168)	123 (22)	8.1 (3.67)	12.63 (321)	46 (21)	14.00 (356)	16 (7.26)

