

# INDUSTRIAL EXCESS FLOW VALVES

H-911 SERIES



**FEATURES**

- Stainless Steel Construction
- MAWP 6000 psi (413 bar)
- MAWT 400°F (204°C)
- Variable connection sizes (1/8 to 1/2" & 6 to 12mm)
- Cv = 0.5 ; 1.1
- Safety System Shutoff Device

**GENERAL**

1. The poppet is loaded by a spring in a normally open position as long as the system is balanced.
2. If the system becomes unbalanced and the downstream pressure drops, the poppet moves towards the sealing area and prevents free, uncontrolled excess flow from the line.
3. If the downstream pressure increases, the ventilation outlet ("bleeding") enables the system to balance the pressures and (with the help of the spring) reset the system. In this situation, the poppet reverts back to Normally Open.

Excellent for Automatic Safety Shutoff in a wide range of areas:

- Fuel systems ■ Toxic Media Systems ■ Gas Systems ■ Valued Media Systems
- Hydraulic & Pneumatic Systems.

**OPERATING PRINCIPLE**

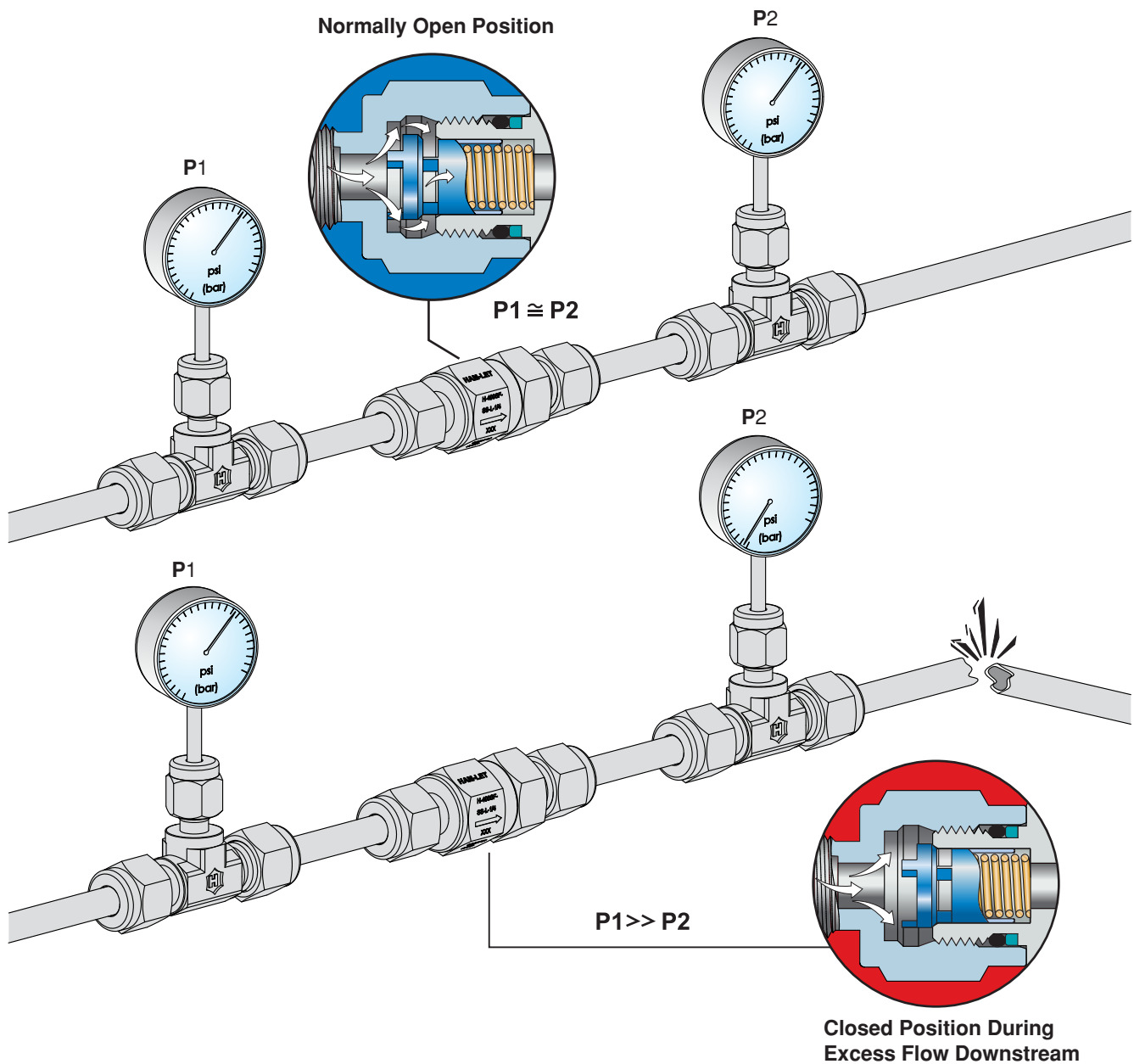

## CLEANING & PACKAGING

Every H-911 series Excess flow valve is cleaned in accordance with Standard Cleaning and Packaging (procedure 8184). Oxygen Clean & Lubricant Free Cleaning and packaging, in accordance with Special Cleaning and Packaging (procedure 8185), is available as an option.

## TESTING

The design of the H-911 Valves has been tested for Proof and Burst. Every assembled valve is tested for proper functionality.

MATERIALS OF CONSTRUCTION			
Item.	Components	Qty.	Valve Body Material
1	Insert	1	St.St.ASTM - 276
2	Back Up	1	Fluorocarbon FKM
3	O-ring	1	Fluorocarbon FKM
4	Body	1	St.St.ASTM - 276
5	Spring	1	St.St. 302
6	Poppet	1	St.St.ASTM - 276

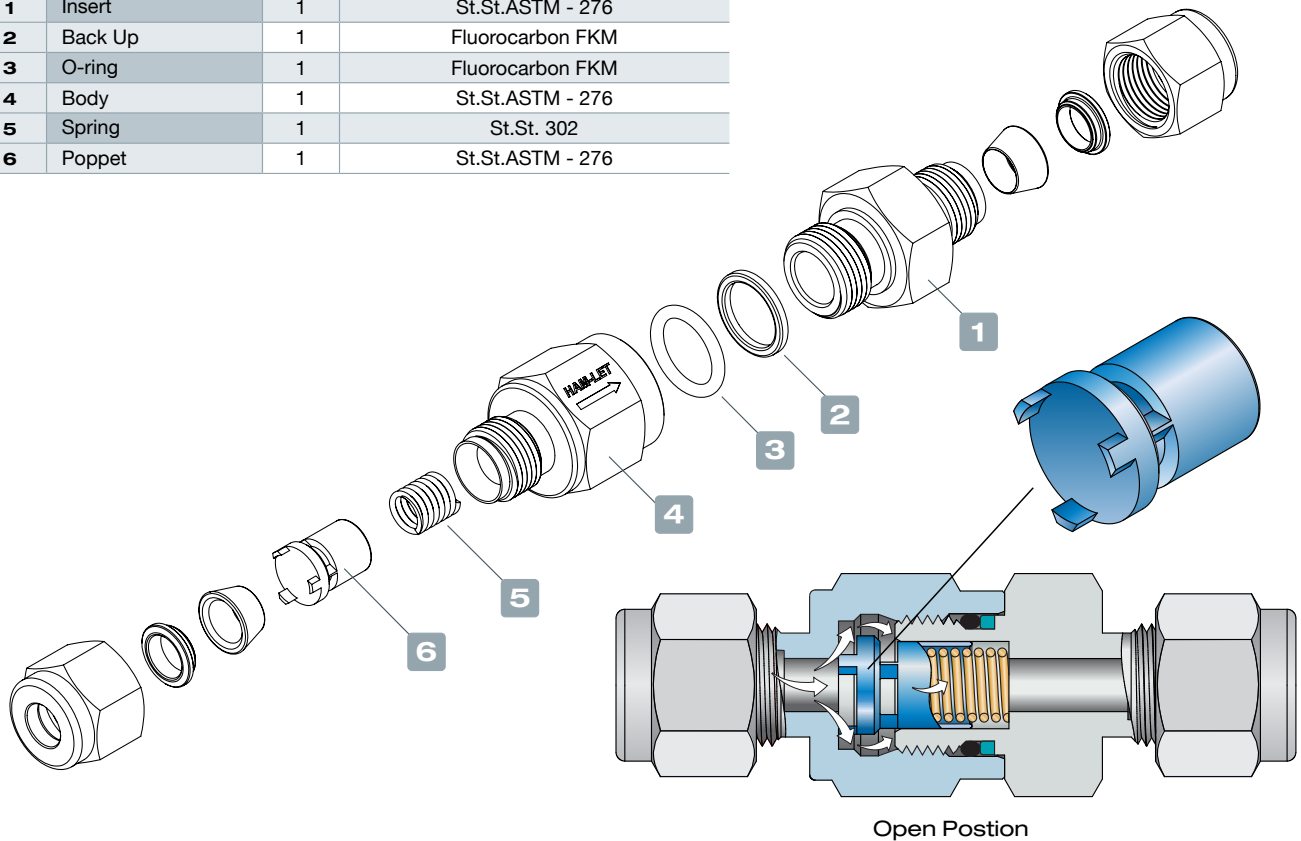

### 5 Spring

Resets the system back to the normally open position when the downstream pressure equalizes the upstream pressure.

### 6 Poppet

- Produced from stainless steel.
- Enables high flow rates.
- Improves reliability and performance.

### Vent "Bleeding"

Enables "information transfer" between the two sides of the valve, and automatically resets the system.

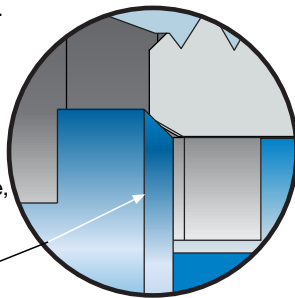

### Metal Sealing

Improves stability and repeatability. Does not need maintenance.

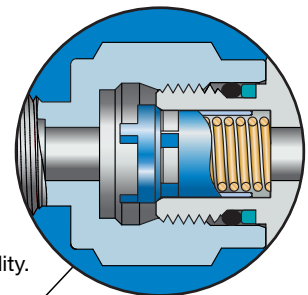

Closed Position

### PRESSURE TEMPERATURE RANGES

- The estimate refers to O-Rings and back up made from Fluorocarbon FKM.
- For O-Rings made from other materials, see ordering information.
- 5000 psi (344 bar) for the H-911 Series with end connections 3/8 NPT female.
- 4600 psi (316 bar) for the H-911 Series with end connection 1/2 NPT female.

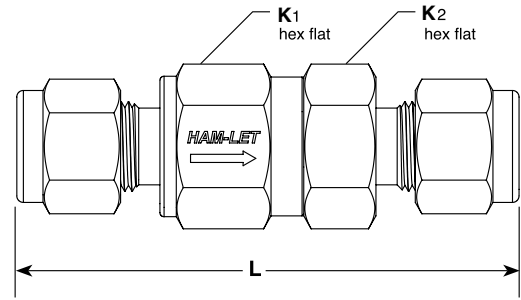

PRESSURE TEMPERATURE RANGES FOR 316 St.St	
Temperature F° (C°)	Working Pressure, psi (bar)
-10 (-23) to 100 (37)	6000 (413)
200 (93)	5160 (355)
250 (121)	4910 (338)
300 (148)	4660 (321)
400 (204)	4280 (294)

PRESSURE TEMPERATURE RANGES	
O-ring Material	Temperature Rating F° (C°)
Fluorocarbon FKM	-15° to 400 (-26 to 204)
Buna-N	-40° to 250 (-40 to 121)
Ethylene propylene	-50° to 300 (-45 to 148)
Perfluor	-10° to 400 (-23 to 204)
Polychloroprene (CR)	-40° to 250 (-40 to 121)

Fluorocarbon FKM O-Rings are standard.  
 For other O-Ring materials, see ordering information.  
 For O-Ring materials that are not in this table, please consult HAM-LET.

STANDARD CONFIGURATION DIMENSIONS				
End Connection		Dimensions: inch (mm)		
Type	Size	L	K1	K2
LET-LOK® Tube Fittings	1/4"	2.43 (61.7)	11/16	11/16
	3/8"	2.75 (69.9)	1	1
	1/2"	2.97 (75.4)	1	1
	6 mm	2.43 (61.7)	11/16	11/16
	8 mm	2.70 (68.6)	1	1
	10 mm	2.80 (71.1)	1	1
	12 mm	2.96 (75.2)	1	1
Female NPT	1/8"	1.87 (47.5)	11/16	11/16
	1/4"	2.12 (53.8)	11/16	11/16
	3/8"	2.55 (64.8)	1	1
	1/2"	3.03 (77.0)	1	1
Male NPT	1/8"	1.79 (45.5)	11/16	11/16
	1/4"	2.17 (55.1)	1	1
	3/8"	2.36 (59.9)	1	1
Male NPT to LET-LOK® Tube Fittings	1/2"	2.73 (69.3)	1	1
	1/4"	2.30 (58.4)	11/16	11/16
	3/8"	2.56 (65.0)	1	1
Male to Female NPT	1/2"	2.85 (72.4)	1	1
	1/4"	2.13 (54.1)	11/16	11/16
	3/8"	2.46 (62.5)	1	1
Male Face Seal	1/2"	2.89 (73.4)	1	1
	1/4"	2.28 (57.9)	11/16	11/16
	1/2"	2.73 (69.3)	1	1

Dimensions are for reference only, and are subject to change.

**FLOW DATA AT 70°F (20°C)**

For springs with other trip ranges, consult a HAM-LET representative.

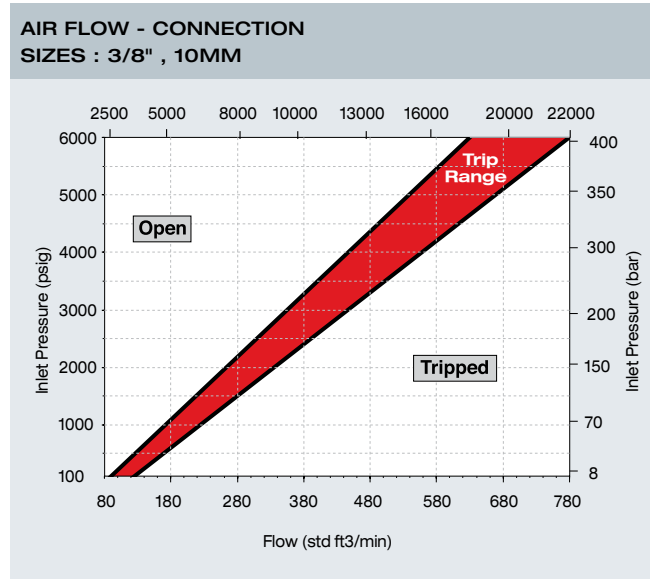
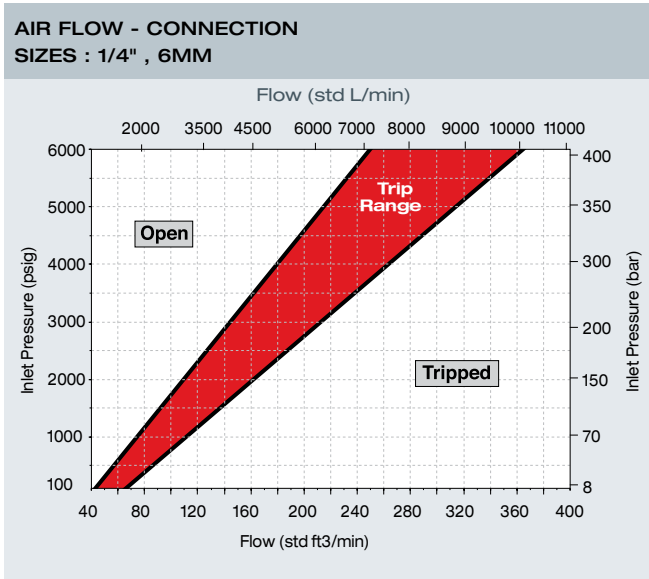

**WATER FLOW**

Connection Size	CV	Trip Range U.S. gal/min (L/min)
1/8, 1/4, 6mm	0.5	3.9 to 5.8 (14.7 to 21.9)
3/8, 8mm, 10mm	1.1	8.2 to 10.0 (31.0 to 37.9)
1/2, 12mm		11.2 to 14.9 (42.4 to 56.4)

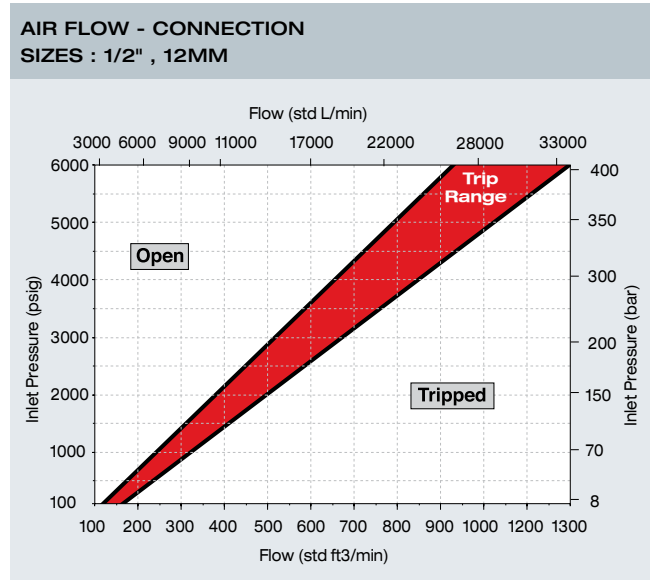

**H-911 SERIES ORDERING INFORMATION**

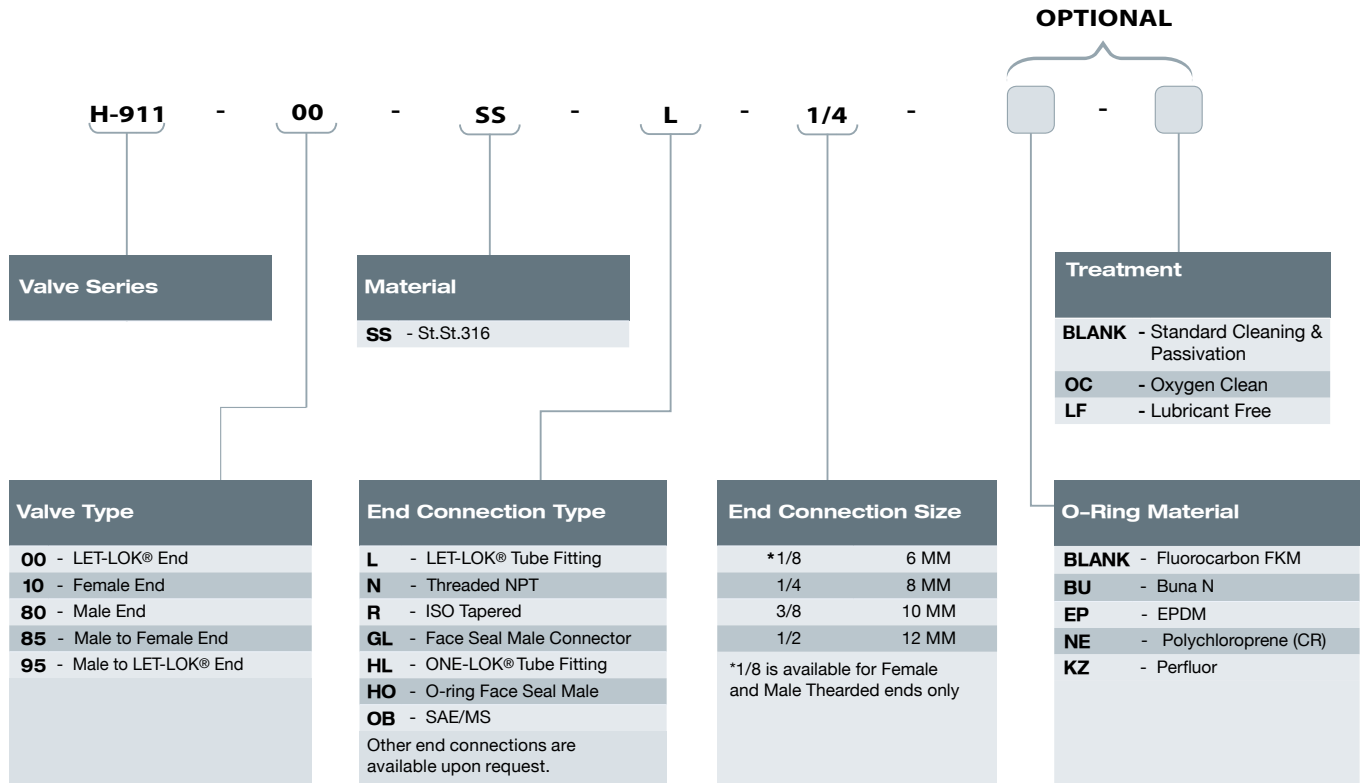

**Warning!**

The system designer and user have the sole responsibility for selecting products suitable for their special application requirements, ensuring their safe and trouble-free installation, operation, and maintenance. Application details, material compatibility and product ratings should all be considered for each selected product. Improper selection, installation or use of products can cause property damage or personal injury.

H-911, Rev.08, January 2014